

## Hit & Miss Enterprises

P.O. Box 157 - 4462 Montgomery Rd. - Orwell, OH 44076

PH: (440) 272-5335 FAX: (440) 272-5333

Mon-Fri 9AM-5:00PM (EST) Sat. No regular hours. Drop-ins\*Best to call first.

*No Sunday's or Holidays Please*

E-mail: [sales@hitnmiss.com](mailto:sales@hitnmiss.com) \*\*\*\*\* Web page: [www.hitnmiss.com](http://www.hitnmiss.com)

2011

Jan. 1, 2011

**OUR GUARANTEE** is everything we sell must be as we represent it. If you find a minor problem with a part and are willing to correct it yourself let us know and we'll give you a credit toward your next purchase. Unless stated otherwise all the parts in our catalog are new. However, we may substitute a good original used part if we are out of new stock.

**TERMS:** For your convenience we accept MasterCard & Visa ( minimum of \$10.00 on credit card orders with the exception of literature or add to orders). If prepayment is desired personal checks are OK (U.S. only). Canadian and overseas payments must be by credit card (Visa, M/C or Discover). We do not quote shipping and charge it on a separate invoice after we mail your parts. A copy of this invoice will be mailed to you.

**\*\*\* We process all credit cards and checks or money orders when the order is wrote up.**

**SHIPPING AND HANDLING** is extra on all orders. U.S. customers please include \$4.00 for literature orders and a \$8.00 minimum for parts orders. Allow more on heavy items.

**\*\*\*Please allow three-four weeks for shipping. \*\*\*Conditions beyond our control may cause delayed shipping or backorders.** Please remember we are not just a distributor. A big percentage of our parts are manufactured here and are made after we receive orders for them. We have up to 4 machinists (two full time) and due to all the repair work and part's being made they are sometimes very hard pressed to meet our desired shipping goal. On the other hand we have many orders that do go out within one week We appreciate your understanding and cooperation.

### Just to Prevent Misunderstandings

- We process all credit cards and checks or money orders when order is wrote up.
- Please allow 3-4 weeks from time of order to ship date.
- We guarantee our parts and service. That doesn't mean we always get it right the first time. Many times due to confusion on ordering parts a collector ends up with some parts that are unusable, and we make our share of mistakes also. Part's books are sometimes very vague or non-existent and we have to depend on our 35 years of experience to assist you in your part's search.
- Please give us plenty of lead time in helping with your restoration. Your patience makes our job such a pleasure.

Thank You!

Map to Hit & Miss Enterprises

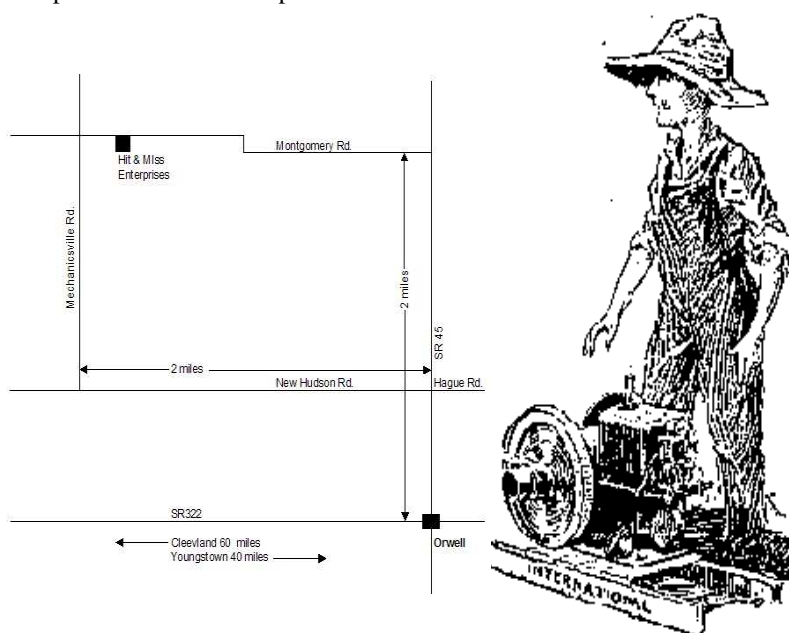

**“A MESSAGE FROM ED”** I’m the guy that got it all started about 40 years ago. I love old iron and I was and still am a collector who saw a need in the hobby for part’s suppliers. We’ve come a long way and it is my good fortune to have a wife (Donna) and son (Anthony) who are just as dedicated to our hobby and the parts business as myself, assuring that with the good Lord willing, Hit & Miss will be providing parts and service for many years.

Now we have a lot of parts and that’s a fact. Unfortunately, it’s also a fact that what we have parts for is a drop in the bucket compared to the many engines manufactured from 1900 to approximately 1940. That means some of you won’t find your engine listed here. Sometimes you get lucky when you call us, but all too often we have to disappoint you and I hate that. I thank all of you for your support, whether you’ve purchased parts or just stopped by to visit us at the shop or at the shows. We’re committed to getting the old iron going and will continue to work on improving our offering of parts to you. Following is a list that may be helpful, especially to those of you who are having a difficult time finding parts.

**LOCATING PARTS:** Hit & Miss is a good place to start, but if no luck here try other part’s dealers, “For Sale” ads, the internet (Harry’s Old Engine Page, <[www.old-engine.com](http://www.old-engine.com)>, etc.) I also suggest that you subscribe to one of the magazines devoted to old iron. For instance, just about all the gas engine supplier’s advertise in GEM and it’s also a good place to run a want ad. Give the ad a chance. Run it for several months if necessary. Attend all the engine shows & swap meets you can and be sure to have measurements, samples, etc. with you. If you find an engine like yours, a camera, pencil and paper, and measuring tape will come in handy. You’ll have a picture of exactly what you need and the necessary specifications to help you in finding or reproducing the parts.

**SOME PARTS ARE AVAILABLE FOR ALL ENGINES:** We can supply custom made insert bearings & valves (No tractor or diesel), new pistons (3-3 1/2" inc. oversize), piston rings, gasket material, oilers, oiler glass, grease cups, draincocks, sparkplugs, ignition wire, mica for ignitor repair, babbitt stock to pour your own bearing (also damming clay and flux), coils, and more.

**REPAIR & CUSTOM WORK:** Besides our custom made valves & bearings, we offer expert magneto and ignitor repair, rebuilding carbs (mixers), fuel pumps, cylinder heads, etc., fabricating and machining new parts, custom made fuel tanks, and repair or dupli-cation of most parts from original part or drawings. We do not bore or sleeve blocks but can offer some references.

**LOOKING FOR ADVISE? We recommend you go to [old-engine.com] and post a message on “SmokStak”.** As Ed is trying real hard to be a little more retired he just won’t be able to continue the free advice we’ve offered for many years. He will still be here but no set hours. The person who answers the phone will take all your info and if they can’t answer questions concerning your part’s order for new or used parts someone will call you back. You may also email us for assistance in ordering the correct parts for your engine. And not to worry-Ed or Anthony (or Donna) will be there to get on the phone with the sales person to assist as needed, just not for general advice calls such as engine problems, engine values, etc. “SmokStak” is the place to go for a bunch of friendly guys willing to help answer your questions. Ed’s been doing this for 40 years and hopes you all understand.

## CATALOG INDEX

Aermotor	4	F/M Ignitor Fired 3-6HP	6-7	Literature	24-25-26	Red Brass Pipe	30
Alamo-Empire	4	F/M Sparkplug Fired	7-8-9	Lunkenheimer	22	Shim Stock	33
Alpha-Lauson	5	F/M Style ‘C’	9	Magneto Parts		Spark Plugs	3
Associated-United	5	F/M “ZC” 118, 208, 346	10-11	Bosch “AB-33, 34	3	Specialty Nuts	33
Babbitt	26	F/M Style ‘D’	9-10	F/M type ‘J’	3	Steam Related	23-24
Babbittite	26	Fuel Line (copper, rubber)	32	F/M type ‘R’ & ‘RV’	3	Steel Pipe & Fittings	31
Barb Fittings	32	Fuel Tank necks and caps	26	IHC ‘HI’	3	Stover	
Bar Stock-Alum. & brass	32	Fuller Johnson	11	John Deere	18	‘K’ & ‘KE’	19-20
Belting	28	Galloway	11	Webster	3-4	“CT”	20-21
Belt Lacing	28	Gasket Material	26	WICO ‘AH’	4	Studs	33
Black Pipe & Fittings	31	Gib Keys	27	WICO ‘EK’	4	Taper Pins	33
Brass Mesh Wire	26	Gib Key Puller	27	Monitor 1 1/4HP “VJ”	18	Witte	
Brass Pipe & Fittings	29-30	Grease Cups	26	Mufflers, cast iron	22	Head Type	21
Check Balls	27	Hardware & Misc	32-33	Nameplate fasteners	32	Headless	21
Check Valves (fuel)	26,32	Hercules	11-12-13	Nelson Bros “U or T”	18		
Coil, Ignitor	3	‘XI’-‘XK’	13-14	New Sattley	18		
Cotter Keys (brass)	32	‘JI’-‘JK’	14	Novo model ‘S’	19		
Crankhandles	22	Ideal “air-cooled”	14	Oilers, engine	27		
Cushman ‘C’	5-6	Ignition Parts	3	Oiler gaskets	27		
Cushman ‘R’	6	IHC-McCormick Deering		Oiler glass	27		
Draincocks	26	Model ‘M’	14-15-16	Oil Cups	27		
Drill Rod	32	Model ‘LA/LB’	16-17	O-Ring, copper	26		
Economy (Hercules)	11, 12, 13	Jaeger (Hercules)	11-12-13	Ottawa	19		
Economy Sparta	6	J-B Weld	27	Piston Rings	22-23		
Fairbanks Morse		John Deere	17-18	Priming Cups	27		
Headless 1 1/2HP	6	Kroil	27	Pulleys	22		



# The Electrical Connection Ignition Parts & Repair

## THREE BASIC THINGS TO MAKE AN ENGINE RUN

are fuel, compression, and a good spark. In this section we offer many new parts for high and low tension ignition systems.

By "low tension" we are referring to ignitor equipped engines and magnetos that appear so weak that even with bare feet on wet ground a good mag won't give you much of a shock, if any, let alone jump a spark. To visually check a low-tension mag for spark, rub the end of the leadout wire across the ignitor spring while cranking the engine, or to bench test, hold the wire against the gear cogs while spinning the gear.

"High tension" ignition systems use a sparkplug along with a coil (Model "T" style) or a magneto, that if hot, will definitely get your attention with a spark that will jump 1/4" or more if in good condition.

We may have the parts to repair your mag, but if you don't have a good magnet charger, or if you're prone to be a little unlucky with some unfamiliar mechanical devices, then we suggest you send your magnetos and ignitors to us for the expert repair you expect. Turnaround time on repairs is usually two to four weeks. We sometimes have misc. rebuilt mags and ignitors for sale and may take your parts on trade.

## MISCELLANEOUS IGNITION PARTS

W05	Coil, low tension, 180 ft of winding	52.50
W09	Fahnestock clip (Brass-for coils, etc.)	1.15
W112	Fahnestock clip (bronze), large, for ignitor	2.50
<b>MICA TUBE-1 3/4" LENGTH</b>		
W113A	1/4" ID X 3/8" OD	3.30
W113B	1/4" ID X 7/16" OD	3.30
W113C	1/4" ID X 1/2" OD	3.30
W113D	1/4" ID X 9/16" OD	3.30
W113E	1/4" ID X 5/8" OD	3.30
W113F	5/16" ID X 3/8" OD	3.30
W113G	5/16" ID X 7/16" OD	3.30
W113H	5/16" ID X 1/2" OD	3.30
W113I	5/16" ID X 9/16" OD	3.30
W113J	5/16" ID X 5/8" OD	3.30
<b>MICA WASHERS 3/4" STACK</b>		
W114A	3/16" ID X 5/8" OD	2.75
W114B	3/16" ID X 1" OD	2.75
W114D	7/32" ID X 3/4" OD	2.75
W114H	1/4" ID X 1/2" OD	2.75
W114I	1/4" ID X 5/8" OD	2.75
W114J	1/4" ID X 3/4" OD	2.75
W114K	1/4" ID X 7/8" OD	2.75
W114C	5/16" ID X 5/8" OD	2.75
W114E	5/16" ID X 3/4" OD	2.75
W114F	3/8" ID X 1/2" OD	2.75
W114G	3/8" ID X 1" OD	2.75
W115	Ignitor Points, cheap (per pair), 1/8" dia. stem	4.00

Custom made Ignitor Points from high grade stock-stems are 5/16" long, head is 1/4" dia, 1/16" thick, (or made to your specs.)

W1153A	With 1/8" stem, 1 pair	14.10
W1153B	With 3/16" stem, 1 pair	14.10
W117	Primary wire #14 (per foot)	1.00
W122	Primary wire #12 (per foot)	1.00
W120	Knifeswitch (porcelain)	18.50
W25	Sparkplug wire 7mm (per foot)	1.25
W27	Sparkplug wire end, brass/forked	1.25
W28	Sparkplug wire end, steel/forked	.75
W29	Sparkplug wire end for mag, brass	.25
HM01	Sparkplug 7/8" Autolite 3076	5.00
HM01A	Sparkplug 7/8" Long Reach Autolite 3077	5.75
HM02	Sparkplug 1/2" Pipe thread, Autolite 3095	5.00

## BOSCH Type AB33

L012	AB-33 Inst. & Parts	2.00
HM2593	Bosch AB-33 Holddown Clamp (clamps mag to bracket)	24.00
HM2593A	Holddown Clamp Stud	3.00
HM2591	Lead Out Tower	35.00
HM2592	Point's Cover	12.50
HM2588	Trip Arm 2 3/4"	40.50
HM2589	Trip Arm 5 1/4"-1 1/2HP Application Only	40.50
HM259	Trip Roller & Bolt 1 1/2-2HP *	20.50

## BOSCH Type AB33 cont.

HM2590	Trip Roller & Bolt 3-6HP *	25.50
<b>*Trip Roller &amp; Bolt go on cam gear</b>		
HM261A	Spring, Inductor (Trip Arm)	6.00
HM25910	Spring Roller	4.50

## FAIRBANKS MORSE

### Type "J"

HM2594	Base Plate (To mount FM mags on FM "Z" engines)	20.50
HM2595	Coil	68.00
HM2596	Coil & Points Cover Cap	37.50
HM2597	Condenser	10.75
HM2598	Points Set	22.50
HM260	Key, Drive Gear (Fits "J, R, RV & X Mags)	1.00

### Type "RV"

HM2605	Coil Replacement	72.00
HM2606	Coil Cover	52.50
HM2607	Condenser Replacement	16.00
HM2608	Points	24.00

## IHC H1 MAGNETO (Parts listed here not for Wico H or AH)

L41	H-1 Inst. & Parts	6.50
HM640	Coil	65.50
HM638	Coil Cover (Cap)	24.00
HM639	Condenser	11.50
HM6315	Gasket, Magneto to Coil Cover	1.75
HM633	Gasket, Mag Points Cover	1.75
HM6405	Gasket Kit	6.50
HM642	Impulse Spring, H1 only	22.50
HM641	Points	12.50
HM6415	Points Cover	22.50

## JOHN DEERE MAGNETO (See JD Parts, pages 18-19)

## WEBSTER MAGNETO

Parts listed here are for the "old style" Webster (see drawing). Most engines in the 1-2HP range have an "AMM" or similar type with one magnet, a 2 1/2 to 3 1/2HP usually was equipped with an "AK" type with two magnets.

Larger engines up to 12HP may have the "AL" type with three magnets. "AK" and "AL" mags will interchange and if the mag is in good condition the "AK" will run the larger engines. We sometimes have new and old style rebuilt mags and misc. trip assemblies.

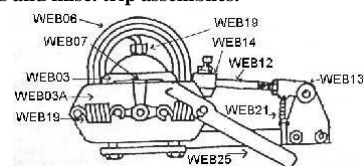

L42	"Old Style" Helps & Hints	2.50
WEB007	Armature Housing-Brass "M" mag	172.50
WEB008	Armature Housing-Brass "K" mag	172.50
WEB01	Coils "AMM" (pair)	72.50
WEB01A	Coils "AK-AL" (pair)	72.50
WEB02	Dust Cover "AMM", Pot Metal Housing	13.50
WEB02A	Dust Cover "AMM", Brass Housing	17.50
WEB03	Dust Cover "AK-AL", Pot Metal Housing	13.50
WEB03A	Dust Cover "AK-AL" Brass Housing	17.50
WEB04	End Plate W/Bearing, Brass	42.50
WEB045	Mag Armature Push Finger K2	35.00
WEB046	Mag Armature Push Finger K3	35.00

(Push finger - keyed part on end of arm shaft that push rod strikes against to trip mag. We'll help you get the right one.)

(Cont. next page)

**WEBSTER MAGNETO (cont.)**

WEB05	Nameplate "AMM", 3/4" x 18"	11.00
WEB06	Nameplate "AK-AL" 1" x 18"	11.00
WEB07	Oiler W/Hinged Lid, Fits into 1/4" Hole	2.50
WEB07A	Oiler W/Spring Loaded Ball, Fits 1/4" Hole	3.00
WEB08	Priming Cup, Essex, Brass, 1/8" P/T	24.00
WEB10	Priming Cup, Original Style, Steel	21.00
WEB11	Trip Finger Assy., All HP's (Not new style)	58.00
WEB12	Trip Push Rod Only	18.00
WEB13	Trip Push Rod Journal Only	20.00
WEB14	Trip Push Rod Wedge Only	20.00
WEB15	Retard Lever With Spring & Shaft	47.50
WEB16	Retard Lever Roller	10.50
WEB17	Retard Lever Spring Only	4.50
WEB18	Spring, Inductor "AMM"	6.00
WEB19	Spring, Inductor, AK-AL"	6.00
WEB19B	Spring Roller	3.00
WEB20	Spring, Trip Finger Journal 1 1/2-2HP	3.00
WEB21	Spring, Trip Finger 2 1/2-12HP	3.00
WEB25	Starting Lever	8.00

**WICO "AH" and 'H' MAGNETO**

L44	"AH" and "H" Inst. & Parts	2.50
HM6424	Coil (Substitute-needs modified), Type 'AH' magneto	75.00
HM643	Coil Cover, Type 'AH' magneto	50.50
HM6423	Condenser, Type 'AH' magneto	17.00
HM632	Gasket, Mag Points Cover, Type 'H' magneto	1.75
HM6325	Gasket, Mag Points Cover, Type 'AH' magneto	1.75
HM6435	Impulse Spring, Type 'AH' magneto only (not "H")	27.50
HM6425	Points, Type 'AH' magneto	17.50

**WICO EK" MAGNETO**

We're always interested in buying or trading magnetos that fit the engines we sell parts for, and we offer a two for one deal; send us two complete dead WICO "EKs" and we'll send you back one (reconditioned and guaranteed). We usually have rebuilt WICO's in stock and we do accept trade-ins. You can depend on us for expert repair on your magnetos along with fast service.

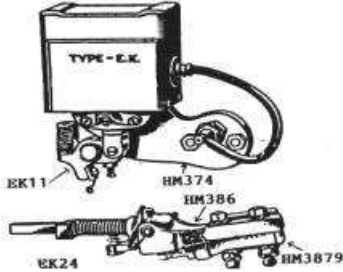

L43	Instructions & Parts Manual	3.00
EK01	Armature Fork Roller, Bolt & Nut (like original)	7.50
EK011	Armature Yolk Assy., Cushman "R" Models	30.50
EK01A	Coil Secondary Con. Spring (Jumper)	1.00
EK02	Coil (Pair)	95.00
EK03	Condenser	10.00
EK04	Cover, Front (with stop button)	19.00
EK05	Cover, Front (without stop button)	17.00
EK06	Cover, Back	13.25
EK12	Cover, Side Band	26.50
EK065	Gasket, Coil (#206)	2.75
EK066	Gasket, Deck (#236)	2.00
EK07	Lead Out Tower With Spring	6.50
EK08	Nameplate W/Rivets	6.00
EK09	Points with Felts	14.00
EK10	Point's Felt	.50
EK105	Rear Frame (Assembly Plate #200)	42.50
EK107	Deck Frame (Deck Half Group #207)	49.50
EK11	Rocker Arm Group	27.50
EK11A	Rocker Arm Latch Block	7.50
EK13	Armature Return Spring - (Type 1)	4.00
EK14	Armature Return Spring - (Type 2)	4.00
EK15	Armature Return Spring - (Type 3)	4.00
EK16	Armature Return Spring - (Witte)	4.00
EK17	Mag Drive Spring - (Type 1)	4.00
EK18	Mag Drive Spring - (Type 2)	4.00

**WICO "EK" MAGNETO (cont.)**

EK19	Mag Drive Spring - (Type 3)	4.00
EK20	Mag Drive Spring - (Witte)	4.00
<b>(Don't see your springs here? Call for help)</b>		
EK21	Trip Finger Support Spring # 2	2.00
EK22	Support For # 2 Armature Spring	9.00
EK23	Support Rocker Stud & Nut	12.50
EK24	Trip Finger Assembly # 413, Type 2	65.10
EK25	Trip Finger Latch Group, Type 2	25.00
EK26	Trip Finger Frame Group With Retard Lever	35.75
EK27	Trip Finger Retard Lever Type 2	4.50
EK272	Trip Rocker Retard Lever - (C- Shaped) Type 3	4.50

**ENGINE PARTS LISTING**

**AERMOTOR "8 CYCLE" PUMP ENGINE**

(With governor in flywheel)

L005	Setting up & Operating	1.00
LS2	"For Pumping And Power"-Catalog	3.00
HM011	Crankguard	20.50
HM012	Carb (Mixer) Needle Valve	18.50
HM013	Carb Needle Valve Bushing	16.00
HM0135	Exhaust Rocker Arm (Machined casting only)	77.50
HM0136	Exhaust Rocker Detente Latch	18.50
HM0137	Exhaust Rocker Roller	14.00
HM0138	Exhaust Rocker Roller Pin	12.50
HM0139	Fuel Tank	47.50
HM01392	Fuel Tank Spacer	14.00
HM014	Gear Shield	48.50
HM0142	Ignitor Trip Arm	37.50
HM0145	Piston, cast iron, like original, oversize available	162.50
HMR13	Piston Ring 3" X 1/4"	6.00 ea.
HM015	Spring, Ignitor Tension	6.00
HM016	Spring, Ignitor Torsion	6.00
HM020	Valve, Exhaust	30.25
HM021	Valve, Intake	30.25

**ALAMO-EMPIRE-ROCK ISLAND**

L08	Instruction & Parts, Type "A", 1-16HP	6.00
M045	Bearing, Rod 1 1/2HP, 1 1/4" Shaft	31.50
M048	Carb (Mixer) Needle Valve 1 1/2-3 1/2HP	18.50
M050	Decal, Alamo	6.00
M051	Decal, Empire	6.00
M052	Decal, Rock Island	6.00
M060	Ex. Rocker Lever, Alamo 1 1/2HP	35.75
M061	Ex. Rocker Lever, Alamo 2 1/2HP	37.00
M062	Ex. Rocker Lever, Alamo 3HP	38.10
M065	Gasket (copper o-ring), Ignitor (all)	5.00
M072	Muffler, Alamo 1 1/2HP 1" NPT	75.00
M073	Muffler, Alamo 2 1/2HP 1 1/4" NPT	0
M080	Spring, Ex. Valve, Alamo 1 1/2HP	6.00
M081	Spring, In. Valve, Alamo 1 1/2HP	6.00
M082	Spring, Ex. Valve, Alamo 2 1/2-3HP	6.00
M083	Spring, In. Valve, Alamo 2 1/2-3HP	6.00

**\*\*PRICE INCREASES\*\* We have some price increases from our supplier's on a regular basis but try to absorb as many of these as we can. If you receive a part with a higher amount shown on the invoice than in our catalog this is the reason. You have the option of returning any part if you feel the increase is unsatisfactory to you.**

**ALPHA DELAVAL (Lauson)**  
**Type "F" 1 1/2W, 2 1/2WA, 3 1/2WB**

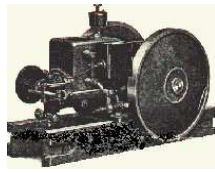

L01	Inst. & Parts, 1½-3½HP, with WICO "EK"	2.50
ALP001	Bearing, Rod 1½HP	31.50
ALP002	Bearing, Rod 2½HP	32.50
ALP003	Bearing, Rod 3½HP	38.00
ALP004	Bearing, Main 1½HP	35.00
ALP008	Carb Air Damper (Choke) 1½HP 168A	6.00
ALP009	Carb Needle Valve 173 (all HP)	16.25
ALP010	Carb Needle Valve Seat 316A (all HP)	19.25
ALP015	Exhaust Rocker Lever 17A 1½HP only	40.25
ALP0152	Exhaust Rocker Lever 2 1/2HP	42.25
ALP017	Exhaust Rocker Lever Pin 78 (all HP)	7.50
ALP020	Exhaust Push Rod Fork 89A (all HP)	39.75
ALP025	Fuel Tank 1 1/2HP	55.50
ALP030	Gasket, Cyl. Head 1½ HP (engines with 3 5/8" piston)	8.00
ALP040	Mag Bracket (WICO) 124-C 1½HP (Sparkplug in head)	38.00
ALP041	Mag Bracket (WICO) (Sparkplug hole in bracket)	75.00
	<b>**Not sure which mag bracket? Call-we can help.</b>	
ALP042	Magneto Assy. Swivel Pin 338 (all HP)	19.25
ALP044	Magneto Retard Sleeve & Pin 328-329 (all HP)	19.25
ALP045	Magneto Trip Rocker 325 (all HP)	42.25
ALP050	Magneto Trip Operating Lever 326 (all HP)	38.00
ALP051	Magneto Trip Operating. Lever Screw 327 (all HP)	14.10
ALP052	Magneto Trip Rod 331 1½HP Only	15.75
ALP054	Magneto Trip Sleeve 332 (all HP)	9.00
ALP060	Piston 3 1/4" to 3 5/8" (Up to .030 O/S available)	162.50
ALP062	Piston Wrist Pin 1 1/2HP (Give piston diam.)	15.75
HMR27	Piston Ring 3 5/8" X 3/16"	6.00 ea.
HM01	Sparkplug	5.00
ALP065	Spring, Exhaust valve (all HP)	4.40
ALP066	Spring, Intake valve (all HP)	4.40
	<b>(We substitute Stover springs- they may need to be shortened)</b>	
ALP067	Spring, Gov. Détente 92 (all)	3.00
ALP068	Spring, Magneto Drive (WICO "EK") 335	4.00
ALP069	Spring, Magneto Return (WICO "EK") 336	4.00
ALP075	Valve, Exhaust 1½HP	31.50
ALP077	Valve, Exhaust 3½HP	33.75
ALP080	Valve, Intake 1½HP	31.50
ALP082	Valve, Intake 3½HP	33.75

**ASSOCIATED-UNITED 1 ½-12HP**

L02	Inst. & Parts, Associated 1 1/2-18HP	6.00
L645	Inst. & Parts, United "Type A" 1 1/2-15HP	4.00
HM024	Bearing, Rod CHC 1 1/2HP	31.50
HM025	Bearing, Rod CGM 1 ¾-2 ¼ HP	31.50
HM0251	Bearing, Rod DEA 3HP	34.25
HM0252	Bearing, Rod CGH 4HP	38.50
HM0255	Cam Roller, DTF Ex. Pushrod 1 ½-8 HP	15.75
HM0255A	Cam Roller Pin DTH 1 ½-4HP	15.75
HM027	Carb Needle Valve AEM 1 1/2-12HP	20.50
HM0275	Carb Needle Seat DPP 1 1/2-2 1/4HP	18.50
HM028	Carb Bushing AEP 1 1/2-12HP	18.50
HM0285	Check Valve, Fuel, In-Line (Globe Type)	26.00
HM031	Crankguard CZR 1 1/2HP	27.50
HM032	Crankguard AGY 1 3/4-2 1/4HP	30.00
HM033	Crankguard DFE 3HP	35.00
HM036	Decal (All Engines)	5.00
HM037	Exhaust Valve Lever CHK 1 1/2HP	39.10
HM038	Exhaust Valve Lever AEB 1 3/4-2 1/4HP	39.10
HM039	Ex. Valve Lever DDD 3HP	42.50
HM0392	Ex. Valve Lever Pin ADH 1 1/2-3 HP	20.50
HM0394	Ex. Pushrod Guide Clamp ACS 1 ½-4 HP	27.50
HM026	Gasket, Carb to Head 1 1/2-2 1/4HP	2.00
HM0289	Gasket, Head 1 1/2HP	7.50

**ASSOCIATED cont.**

HM029	Gasket, Head 1 3/4 (2 1/4 Air Cooled)	8.50
HM030	Gasket, Head 2 1/4 Water Cooled	8.50
HM0301	Gasket, Head 3HP	10.50
HM0302	Gasket, Head 4HP	12.00
HM0303	Gasket, Head 6HP	14.00
HM044	Gasket, Ignitor 1 1/2-12HP	3.00
HM0395	Gov. Collar AEH 1 ¾-2 ¼ HP	39.10
HM0397	Gov. Détente Lever Assy. (complete) ACA 1¾-2¼ HP	118.25
HM0398	Gov. Détente Lever Pivot Pin ADK 1¾-4 HP	13.25
HM040	Gov. Detente or Catch Block 1 1/2-4HP ADZ	19.25
HM041	Gov. Detente Roller ACV 1 1/2-8HP	10.00
HM042	Gov. Detente Adj. Needle ACU	18.50
HM0438	Ignitor Anvil	38.50
HM0455	Ignitor Trip Assy. (complete), "pick," type GDD for 1¾-2¼ HP	159.50
HM047	Mag Leadout, replaces G322	10.50
HM048	Muffler, 1 1/2HP, Cast Iron 3/4"NPT	46.75
HM049	Muffler, 1 3/4HP-2 1/4HP, Cast Iron 1" NPT	46.75
HM052	Nameplate, 1 3/4HP Chore Boy	18.50
HM053	Nameplate, 2 1/4HP Hired Man, hopper cooled	18.50
HM054	Nameplate, 2 1/4HP Hired Hand, Air-cooled	18.50
HMR28	Piston Ring 3 5/8" X 1/4", 1 1/2HP	6.00 ea.
HMR31	Piston Ring 3 3/4" X 1/4", 1 3/4HP	6.00 ea.
HMR34	Piston Ring 4" X 1/4", 2 1/4HP	8.00 ea.
HMR42	Piston Ring 4 1/2" X 1/4", 3HP	8.00 ea.

**(See Piston Rings-page 22-for larger sizes)**

HM9253	Pulley 4"X4", Set Screw Only 1 3/4-2 1/4HP*	75.00
HM9263	Pulley 4"X4", Set Screw & Keyway 1 3/4-2 1/4HP*	83.10
	<b>*Cast iron-for shafts up to 1 1/2" dia. (give dia. and width of keyway)</b>	
HM043	Spring, Gov. Weight ACG (Give HP)	4.00
HM0435	Spring, Gov. Weight Adjusting Screw (All) ACY	5.50
HM045	Spring, Ignitor Tension ACC 1 1/2-12HP	6.00
HM046	Spring, Ignitor Trip "Pick" FTT (All)	12.00
HM060	Spring, Exhaust Valve FCS 1 1/2-2 1/4HP	5.50
HM061	Spring, Intake Valve FRT 1 1/2-2 1/4HP	5.50
HM063	Valve, Exhaust ADA, 1 3/4-2 1/4HP	31.50
HM064	Valve, Intake ADB, 1 3/4-2 1/4HP	31.50
HM065	Valve, Exhaust DET, 3HP	33.75
HM066	Valve, Intake DES, 3HP	33.75
HM067	Valve, Exhaust BMK, 4HP	38.10
HM068	Valve, Intake BMB, 4HP	38.10
HM069	Valve, Exhaust ANL, 6HP	44.00
HM070	Valve, Intake AME, 6HP	44.00

**CUSHMAN "C" VERTICAL 4-8HP)**

Without going into details, we will simply say that there are several variations of the Cushman vertical engines, including twin cylinder models up to 20HP. Many parts interchange between the single cylinder models and quite a few parts interchange between the 4HP and the twin cylinder 8HP. Sometimes we have to tell you we're not sure what is correct on certain parts or what interchanges, but we'll try to help and we do have some used parts.

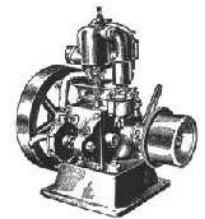

L05	Instruction & Parts 4HP	5.00
L051	Instruction 4-8HP	3.00
L052	Advertising Pamphlet	1.50
HM101	Bearing, Rod, Single Bolt Cap	31.50
HM1011	Bearing, Rod, 4 Bolt Cap	31.50
HM1015A	Carb Float for Schebler	29.50
HM102	Carb Adj. Needle-Schebler	16.25
HM103	Decal	7.00
HM1035	Muffler (Cap, Nipple, & Street Elbow)	27.25
HMR325	Piston Ring 4" X 3/16"	8.00 ea.
HMR34	Piston Ring 4" X 1/4"	8.00 ea.
HM1040	Piston Wrist Pin 4-8HP	24.75
HM02	Sparkplug 1/2" NPT	5.00
HM1045	Timer Contact Spring	19.00
HM1046	Timer Fiber Block	19.00

### CUSHMAN 'C' VERTICAL cont.

HM1047	Spring, Intake Valve	4.40
HM4075	Spring, Exhaust	6.50
HM105	Valve, Exhaust	31.50
HM106	Valve, Intake	31.50
HM108	Valve, Intake, Cage Gasket	3.50

### CUSHMAN "R" CUB

Your Cushman nameplate may identify your engine as a Cushman Cub, Bean Special, Farm Master, or Massey Harris. Horsepower will be from 1½-4HP or from R-2 to R-40. Although many parts interchange there are variations in flywheels, pistons, and heads, but we have the experience to ask you questions that will help you order the correct parts for your engine. Our supply of used parts is usually fair to good.

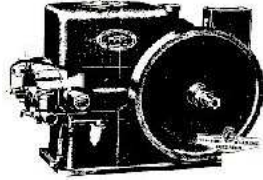

L06	Instruction & Parts Model "R" 2-4HP	2.50
L061	Instruction & Parts Model "R" R2-R40	3.00
HM119	Bearing, Rod (All)	31.50
HM1195	Bushing, Rod	14.10
HM120	Carb-Mixer Body Cap (Brass) 1 1/2"-18 TPI	52.75
HM120A	Carb-Mixer Body Cap (Aluminum)	48.00
HM121	Carb Needle Valve, "R" 1½-4HP	16.25
HM122	Carb Needle Valve, "R" R2-R40	16.25
HM1222	Check Valve, Fuel Line	17.50
HM1223	Check Valve, R-12, R-14 only	17.50
HM1225	Cyl. Hopper Antisplasher (Replacement)	14.00
HM124	Decal, Cushman "Cub" (3 Bears)	7.00 ea.
HM1227	Gasket, Antisplasher	2.00
HM123	Gasket, Cylinder Head	9.50
HM123A	Guide, Exhaust Valve	28.50
HM125	Inspection Plate (over ex. push rod)	14.00
HM1250	Mag Trip Rocker Arm	52.50
HM1250A	Mag Trip Rocker Adj. Bolt	13.75
HM1251	Mag "EK" Armature Trip Yoke Assy.	30.50
HM1252	Main bearing felt washer	2.00
HM1254	Muffler	28.00
HM1255	Piston, (Max. dia. 3.530", give HP)	162.50
HM1257	Piston Wrist Pin (Give piston diameter)	19.25
HMR18	Piston Ring 3/4" X 3/16" *See ring list page 22	6.00 ea.
HMR22	Piston Ring 3/2" X 3/16" for oil rings	6.00 ea.
HMR30	Piston Ring 3/4" X 3/16"	6.00 ea.
HM01	Sparkplug	5.00
HM126	Spring, Mag Drive (WICO EK)	4.00
HM127	Spring, Mag Return (WICO EK)	4.00
HM128A	Spring, Exhaust Valve	4.75
HM130	Spring, Intake Valve	4.75
HM131	Valve, Exhaust	32.50
HM132	Valve, Intake	31.50

### ECONOMY "SPARTA"

M10	Decal (Pair of Horses)	6.00
HM340	Fuel Line Assy. 1½HP	23.25
HM3405	Fuel Line Check Valve Only	15.75
HM343	Fuel Tank, Fills Mag Side 1½HP	52.50
HM344	Fuel Tank, Fills Opposite Mag Side 1½HP	52.50
HM349	Fuel Tank Filler Spout W/Lid 1½HP	41.25
HM352	Gasket, Head 1½HP	8.50
HM357	Gasket, Ignitor 1½HP	3.00
HM358	Gasket, Ignitor 2-10HP	3.00
HM393	Muffler, Ball 1 1/2HP 1" NPT	52.75
HM394	Muffler, Ball 6HP 2" NPT	99.75
M12	Nameplate, Economy Improved, All	15.00
HM3965	Piston (Oversized available)	162.50
HMR20	Piston Ring 1 1/2HP 3/4 X 1/4	6.00 ea.
HMR35	Piston Ring 2 HP 4 X 5/16	8.00 ea.
HMR43	Piston Ring 4 HP 4 1/2 X 5/16	8.00 ea.
M16	Spring, Ignitor 1 1/2HP	6.00
M17	Spring, Ignitor 2-10HP	6.00

### ECONOMY "SPARTA" cont.

HM406	Spring, Exhaust Valve 1½HP	4.75
HM408	Spring, Intake Valve 1½HP	4.75
M 18	Spring, Exhaust Valve 2HP	6.00
M19	Spring, Intake Valve 2HP	6.00
HM415	Valve, Intake or Exhaust 1½ HP	31.50

### FAIRBANKS MORSE "Z" HEADLESS 1½HP

This engine was produced for approximately 3 years (1915-1918) and there was a minor design change or two during this period. The only one that should effect how you order is the style of ignitor your engine uses. We have found at least two different spring set-ups; one ignitor style uses one spring and the other uses two springs. The springs do not interchange. We have some used parts for this engine, but some parts are getting very difficult to locate.

L16	Instruction & Parts	3.00
HM150	Bearing, Rod #176	31.50
HM1502	Bearing, Main #22-23	33.75
HM2047	Bushing, Rod (Wristpin) #17	15.75
HM151	Carb (Mixer) Needle Valve #76	16.25
HM152	Carb Suction Nozzle #263	16.25
HM1525	Crankguard (very nice reproduction-fiberglass)	37.50
HM2675	Crankhandle, Complete #14	71.50
HM268	Crankhandle, Pawl Only	16.00
HM2685	Crankhandle, Pawl Pin Only	2.75
HM225	Decal	4.00 ea.
HM153	Fuel Line, Brass #24	17.50
HM154	Fuel Line Bushing #47	11.50
HM855	Fuel Line Check Valve #19	14.00
HM156	Fuel Tank #15	52.50
HM1568	Gov. Weight Fulcrum Pin #254	19.25
GR05	Grease Cup, Rod #509	11.00
GR07	Grease Cup, Main #505	15.00

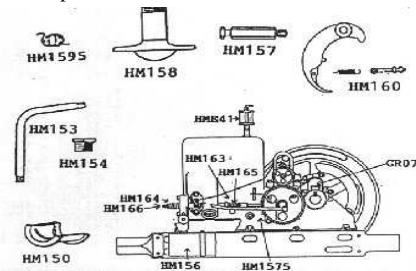

HM157	Ignitor Trip Rod Slide Pin #140	27.10
HM1575	Ignitor Trip Rod #143 (Old Style-One Piece)	38.75
HM158	Muffler #269	31.50
HM1585	Nameplate	18.50
HMR23	Piston Ring 3/2" X 1/4"	6.00 ea.
HM2612	Piston Wrist Pin #7	20.50
HM159	Spring, Crankhandle Pawl #265	4.00
HM1595	Spring, Detente Arm #647	9.50
HM160	Spring, Eyebolt & Nut for governor weight.	19.25
HM161	Spring, Ignitor Tension (2 Spring Ignitor)	6.00
HM162	Spring, Ignitor Torsion (2 Spring Ignitor)	6.00
HM1625	Spring, Ignitor (Single Spring Ignitor)	6.00
HM163	Spring, Exhaust Valve #476	4.75
HM164	Spring, Intake Valve #656	4.75
HM165	Valve, Exhaust #10	31.50
HM165A	Valve, Exhaust Spring Collar #11	20.25
HM166	Valve, Intake #9	31.50

### FAIRBANKS MORSE 3&6HP "Z" IGNITOR Models

These engines were made for approximately 4 years (1916-1919). The carb or mixer mounts on the side of the head above the pushrod and has the fuel pump built in to it, and the ignitor is in the side of the block adjacent to the carb. Sometimes we find the ignitor casting drilled out and tapped to accept a sparkplug along with a high tension magneto. This was an after market replacement sold by F/M and sometimes done by an individual to run the engine with a high tension coil.

**FAIRBANKS MORSE 3&6HP "Z" IGNITOR MODELS cont.**

The early version of this engine used a gear driven mag mounted behind the hopper and the later version used what was called the Plugoscillator (the oscillating mag sat on the ignitor bracket). Each set-up requires a different trip assembly. We have some used parts for this engine, but carbs, mags and ignitors are scarce.

L165	Inst. & Parts, 3-6HP w/rotary mag	5.00
L17	Inst. & Parts, 3-6HP (Plugoscillator)	4.00
HM170	Bearing, Rod, 3HP	35.75
HM171	Bearing, Rod, 6HP	47.25
HM172	Bearing, Main, 3HP	43.00
HM173	Bearing, Main, 6HP	57.50
HM2048	Bushing, Wrist Pin, 3HP	18.50
HM2049	Bushing, Wrist Pin, 6HP	22.75
HM1735	Butterfly Throttle Assy. (goes in head) 3HP	48.25
HM1736	Butterfly Throttle Assy. 6HP	56.25
HM174	Carb Checkball (under plunger)	.50

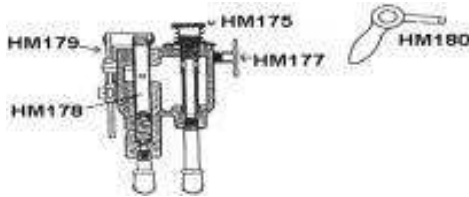

HM175	Carb Drain Valve (Overflow #105)	40.25
HM176	Carb Fill Hole Cover	11.15
HM177	Carb Needle Valve #76A	18.50
HM178	Carb Fuel Pump Plunger #65	27.25
HM179	Carb Fuel Pump Plunger Lever, 3HP #66	44.60
HM1791	Carb Fuel Pump Plunger Lever, 6HP #66	44.60
HM180	Carb Fuel Plunger Lever Lockout #75	21.60
HM1805	Carb Fuel Plunger Spring	2.50
HM1825	Cylinder Head Water Valve Assy.	57.75
HM2246	Crankguard, 3HP-fiberglass ***Nice	47.50
HM2247	Crankguard, 6HP-fiberglass ***Nice	52.50
HM225	Decal	4.00 ea.
HM18261	Ex. Rocker Lever 3HP	47.25
HM18265	Ex Rocker Lever Pin 3HP	20.50
HM18273	Ex. Rocker Lever Bracket 3HP	48.25
HM18285	Ex. Rocker Lever 6HP	48.25
HM18287	Ex. Rocker Lever Pin 6HP	20.50
HM18297	Ex. Rocker Lever Bracket 6HP	49.10
HM181	Gasket, Cylinder Head 3HP	9.00
HM182	Gasket, Cylinder Head 6HP	11.50
HM183	Fuel Tank, 3HP (after eng. #185864)	57.50
HM184	Fuel Tank, 6HP (after eng. #185978) (1916 early style tanks available-please call)	62.50
HM185	Governor Speed Regulator Lever #209	20.50
HM185A	Gov. Speed Lever Leaf Spring #222	16.75
HM185B	Gov. Speed Lever Thumb Screw #224	17.75
HM185C	Governor Throttle Rod, 3HP #205	16.10
HM185D	Governor Throttle Rod, 6HP	17.75
HM185F	Ignitor Trip Blade 3-6HP #54	29.25
HM185G	Ignitor Trip Blade Carrier #52	38.00
HM186	Muffler, 3HP	34.00
HM187	Muffler, 6HP	38.00
HM2613	Piston Wrist Pin 3HP	22.00
HM2614	Piston Wrist Pin 6HP	30.25
HMR43	Piston Ring, 3HP, 4 1/2" X 5/16"	8.00 ea
HMR502	Piston Ring, 6HP, 5 1/2" X 3/8"	14.00 ea.
HM1878	Spring, Butterfly Throttle Assy. 3-6HP	8.50
HM188	Spring, Exhaust Valve 3-6HP	4.75
HM189	Spring, Intake Valve 3-6HP	4.75
HM1892	Spring, Intake Valve Drag 3-6HP	14.50
HM1895	Spring, Ignitor 3-6HP (not for Plugoscillator)	6.00
HM264	Spring, Needle 3-6HP	1.25
HM190	Valve, Exhaust Or Intake, 3HP	35.25
HM191	Valve, Exhaust Or Intake, 6HP	40.25
HM2731	Valve Keeper, Exhaust 3-6HP	7.25
HM2741	Valve Keeper, Intake 3-6HP	7.25
HM2751	Valve Keeper Clip 7/16"	1.00

Requires 1 keeper & 1 clip per valve unless valve has a hole instead of a groove. Please be specific when ordering valve-groove or hole?

**FAIRBANKS MORSE "Z" 1 1/2-6HP SPARKPLUG Models**

This section covers "open-crankcase, sparkplug in head" models manufactured from late 1919 to the early 1930's. This list includes parts for:

- 1-1/2HP Disc or dishpan flywheels, hit & miss, battery and coil ignition, no needle valves in carb.
- 1-1/2HP Bosch oscillating magneto with 2 3/4" or 5 1/4" trip arm, two needle carb, two styles of cam-governor bracket, gears, and camshafts. If not a replacement, cam-gov. brackets are cast iron.
- 2HP Disc or spoke flywheels with gear driven "R" mag or may have "RV" or "J", two needle carb, pot metal cam-gov. bracket (often broken or missing-our replacements are aluminum).
- 3-6HP Bosch mag, may have diagonal or straight cogs on gears, mag uses 2 3/4" trip arm, 1919-1924.
- 3-6HP "R", "RV", or "J" mag with pot metal cam-gov. bracket, straight cogs on gears.
- 5HP Style "B", most of the new parts we offer for the 3HP interchange except for the head gasket and the piston rings. Cyl. bore on this engine is 4 3/4" compared to 4 1/2" for the 3HP.
- 7-1/2HP Style "B"-In comparing the 6HP and 7 1/2HP "B" part's book, there are a lot of subtle changes in the part #'s as if F/M was trying to make it appear as if the 7 1/2 was a completely different engine (being they upped the HP by 1 1/2), but we have found both have 5 3/4" pistons and it appears all the parts interchange. We suggest you order 6HP parts for this model.

NOTE: On any of these engines you should check the width of your rings before ordering replacements as later models and replacement pistons in early models had narrower ring grooves. Gov. weights also vary (check our drawings). Serial numbers are usually found on a boss on the top of the water hopper. Confused?-Please call.

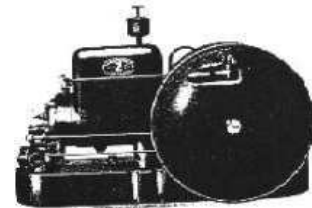

L15	Inst. & Parts 1 1/2-6HP, Bosch, 5 1/4" Trip	4.00
L151	Inst. & Parts 1 1/2-6HP, Bosch, 2 3/4" Trip	4.50
L20	Inst. & Parts 1 1/2HP W/Battery Ignition.	2.50
L14	Inst. & Parts 2-6HP, Gear Driven Mag	4.00
LS51	Sales Catalog 2-6HP with "R" Mag	5.00
L090	Inst. & Parts 5-7 1/2HP Style B,	2.00



HM204	Bearing, Rod 1 1/2-2HP	31.50
HM170	Bearing, Rod 3HP	35.75
HM2041B	Bearing, Rod 5HP (style B with 4 3/4" cyl. bore)	37.50
HM171	Bearing, Rod 6HP	46.75
HM2043	Bearing, Main 1 1/2-2HP	32.00
HM172	Bearing, Main 3HP	43.00
HM173	Bearing, Main 6HP	57.50
HM2047	Bushing, Rod 1 1/2-2HP (For Wrist Pin)	15.75
HM2048	Bushing, Rod 3HP	18.50
HM2049	Bushing, Rod 6HP	22.75
HM205	Butterfly Throttle Assy. W/Spring 1 1/2-2HP	48.25
HM2051	Butterfly Throttle Assy. W/Spring 3HP	53.00

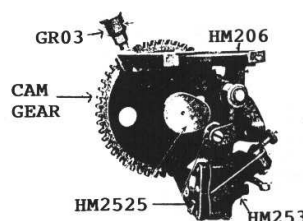

**FAIRBANKS MORSE "Z" 1 1/2 to 6HP SPARKPLUG MODELS cont.**

HM2052	Butterfly Throttle Assy. W/Spring 6HP	53.00
HM206	Cam-Magneto-Gov. Bracket 1 1/2-2HP	165.00
HM2061	Cam-Magneto-Gov. Bracket 3-6HP	190.00
HM207	Carb Air Valve Disc 1 1/2-2HP	3.00
HM208	Carb Air Valve Disc 3HP	3.00
HM2081	Carb Air Valve Disc 6HP	3.00
HM209	Carb Air Valve Cover Plate, 1 1/2-2HP	20.50
HM2095	Carb Air Cap, Cast Iron (for 1 1/2HP "battery" model)	29.50
HM210	Carb Air Valve Cover Plate, 3-6HP	23.75
HM211	Carb Compensating Spring 1 1/2-2HP	3.00
HM212	Carb Compensating Spring 3-6HP	3.00
HM213	Carb Fuel Line Check Valve	4.50
HM214	Carb Fill Hole Cover 3-6HP	15.75
HM215	Carb Fuel Nozzle "Battery" Model 1 1/2HP	19.25
HM216	Carb Needle Valve, Start Side 1 1/2-2HP	16.25
HM217	Carb Needle Valve, Start Side 3-6HP	18.50
HM218	Carb Needle Valve, Fuel Side 1 1/2-2HP	16.25
HM219	Carb Needle Valve, Fuel Side 3-6HP	18.50
HM220	Carb Needle Valve Seat, Start Side 1 1/2-2HP	18.50
HM221	Carb Needle Valve Seat, Start Side 3HP	18.50
HM2211	Carb Needle Valve Seat, Start Side 6HP	18.50
HM222	Carb Needle Valve Seat, (Fuel Side) 1 1/2-2HP	19.25
HM223	Carb Needle Valve Seat, (Fuel Side) 3HP	21.00
HM2231	Carb Needle Valve Seat, (Fuel Side) 6HP	22.00
HM224	Carb. Needle Valve Seat Clamp 1 1/2-2HP	8.50
HM2241	Carb. Needle Valve Seat Clamp 3-6HP	8.50

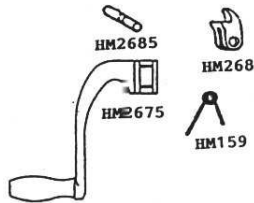

HM2246	Crankguard 3 & 5HP, fiberglass **NICE	47.50
HM2247	Crankguard 6 & 7 1/2HP, fiberglass*LIKE ORIGINAL	52.50
HM2675	Crankhandle 1 1/2-2HP Complete	71.50
HM2672	Crankhandle (Attaches to Flywheel) 1 1/2-2HP Dishpan	31.50
*We sometimes have original 3, 5 & 6HP crankhandles.		
HM268	Crankhandle Pawl Only 1 1/2-6HP	16.00
HM2685	Crankhandle Pawl Pin 1 1/2-6HP	2.75
HM159	Crankhandle Pawl Spring	4.00
HM225	Decal, All Engines	4.00 ea.
HM2255	Detent Bracket "Battery Model"	80.00
HM226	Exhaust Rocker Arm 1 1/2-2HP	35.75
HM227	Exhaust Rocker Arm 3HP	46.75
HM228	Exhaust Rocker Arm 6HP	48.25
HM2282	Exhaust Rocker Arm Bracket 1 1/2HP	30.50
HM2285	Exhaust Rocker Pin W/Oil Cup 1 1/2-2HP	19.25
HM2286	Exhaust Rocker Pin W/Oil Cup 3-6HP	22.00
HM229	Exhaust Push Rod, Battery 1 1/2HP	15.75
HM2295	Exhaust Push Rod Lifter, Battery Model 1/2HP	35.75
HM2297	Exhaust Push Rod Lifter, Battery Model 3HP	37.25
HM230	Exhaust Push Rod 1 1/2HP	15.75
HM231	Exhaust Push Rod 3HP	18.50
HM232	Exhaust Push Rod 6HP	21.00
HM233	Exhaust Push Rod End 1 1/2-2HP	19.00
HM234	Exhaust Push Rod End 3-6HP	20.00
HM2348	Fuel Tank (Battery) 1 1/2HP	52.50
HM235	Fuel Tank (1 pc. steel skid, rounded ends) 1 1/2-2HP	52.50
HM236	Fuel Tank (Bosch Mag., wood skid) 1 1/2-2HP	52.50
HM237	Fuel Tank 3-5HP	57.50
HM238	Fuel Tank 6-7 1/2HP	62.50
HM239	Gasket, Air Valve Plate 1 1/2-2HP	1.50
HM240	Gasket, Air Valve Plate 3-6HP	1.50
HM241	Gasket, Butterfly Housing To Head 1 1/2-2HP	1.50
HM242	Gasket, Carb To "B" Housing 1 1/2-2HP	1.50
HM243	Gasket, Carb To Head 3-6HP	1.50
HM244	Gasket, Cylinder Head 1 1/2-2HP	8.50
HM181	Gasket, Cylinder Head 3HP	9.00
HM2442	Gasket, Cylinder Head 5HP "B" (3/4" cyl)	9.50

**FAIRBANKS MORSE "Z" 1 1/2-6HP SPARKPLUG MODELS cont.**

HM182	Gasket, Cylinder Head 6HP	11.50
HM245	Gasket, Mag Coil Cover Model "J" or "X"	1.50
HM247	Gear, Cam 1 1/2-2HP	149.25
HM2473	Gear, Cam 3-6HP	185.00
HM2475	Gear, Crankshaft Pinion 1 1/2-2HP	80.00
HM2476	Gear, Crankshaft Pinion 1 1/2HP (Diagonal)	87.75
HM2477	Gear, Crankshaft Pinion 3HP	85.50
HM2478	Gear, Crankshaft Pinion 6HP	85.50
HM248	Gear, Gov. With Threads 1 1/2-2HP	50.25
HM2485	Gear, Gov. W/Threads 1 1/2HP (Diagonal cogs)	54.50
HM249	Gear, Gov. With Threads 3-6HP	53.00
HM250	Gear, Gov. & Shaft 1 1/2-2HP	80.00
HM250A	Gear, Gov. (Diagonal Cogs) & Shaft 1 1/2HP	85.75
HM251	Gear, Gov. & Shaft 3-6HP	83.75
HM252	Gear, Magneto 1 1/2-2HP	80.00
HM2521	Gear, Magneto 3-6HP (Not an impulse gear)	85.75
HM2525	Gov. Assy. 1 1/2-2HP (See Illus.)	178.50
HM2525A	Gov. Assy. (Diagonal Cogs on Gear) 1 1/2HP	184.50
HM2526	Gov. Assy. 3-6HP	190.00
HM2527A	Gov. Speed Control Assy 1 1/2 HP (mounts on HM206)	83.50
HM2527B	Gov. Speed Control Assy 3-6HP (mounts on HM2061)	73.50
HM253	Gov. Speed Con. Leaf Spring 1 1/2-6HP	16.75
HM2531	Gov. Speed Con. Thumb Screw 1 1/2-6HP	15.75
HM254	Gov. Spindle Rod 1 1/2-6HP	18.50
HM2541	Gov. Spindle Adj. Screw 1 1/2-6HP	9.50
HM255	Gov. Throttle Rod, Carb 1 1/2-2HP	19.25
HM256	Gov. Throttle Rod, Carb 3HP	20.00

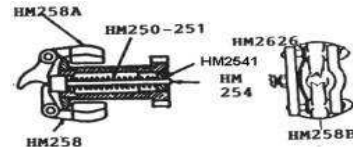

HM257	Gov. Throttle Rod, Carb 6HP	21.00
HM2575	Gov. Thrust Washer 1 1/2-6HP	1.50
HM258	Gov. Weight 1 1/2-6HP- (See Illus.)	16.25
HM258A	Gov. Weight W/Ball 1 1/2-6HP	16.25
HM258B	Gov. Weight (with notch)	16.25
HM2581	Gov. Weight Pin 1 1/2-6HP	1.00
HM2626	Gov. Weight Drag Spring 1 1/2-6HP	5.50
HM2585	Governor Yoke 1 1/2-6HP	47.00
GRO5	Grease Cup 1 1/2-2HP, 1" Dia.	11.00
GRO7	Grease Cup-Main 1 1/2-2HP, Rod 3-6HP	15.00
GRO8	Grease Cup-Main 3-6HP, 1 1/2" Dia.	15.50
HM2588	Magneto Bosch Trip Arm AB-33 2 3/4"	39.50
HM2589	Magneto Bosch Trip Arm AB-33 5 1/4"-1 1/2HP	39.50
HM259	Magneto Bosch Trip Roller & Bolt 1 1/2-2HP *	20.50
HM2590	Magneto Bosch AB-33 Trip Roller & Bolt 3-6HP *	25.50
<b>*Trip Roller &amp; Bolt go on cam gear</b>		
HM2591	Magneto Bosch AB-33 Lead Out Tower	35.00
HM25910	Magneto Bosch AB-33 Inductor Spring Roller	4.50
HM2592	Magneto Bosch AB-33 Pts. Cover	12.50
HM2593	Magneto Bosch AB-33 Holddown Clamp	24.00
HM2593A	Magneto Bosch AB-33 Holddown Clamp Stud	3.00
HM2594	Magneto FM "J" Base Plate	20.50
HM2595	Magneto FM "J" Coil	68.00
HM2596	Magneto FM "J" Coil & Points Cover Cap	37.50
HM2597	Magneto FM "J" Condenser	10.75
HM2598	Magneto FM "J" Points Set	22.50
HM260	Magneto Gear Key (Fits "J, R, RV & X Mags)	1.00
HM2599	Magneto FM "R" Lead Out Tower	42.00
HM2605	Magneto FM "RV" Coil Replacement	72.00
HM2606	Magneto FM "RV" Coil Cover	52.50
HM2607	Magneto FM "RV" Condenser Replacement	16.00
HM2608	Magneto FM "RV" Points	24.00
HM261	Muffler 1 1/2-2HP	27.50

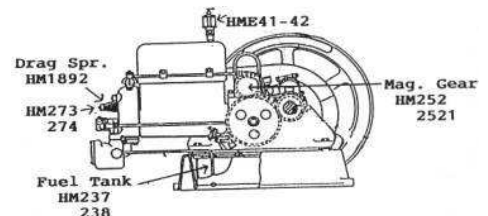

**FAIRBANKS MORSE "Z" 1 1/2-6HP SPARKPLUG MODELS cont.**

HM186	Muffler 3HP	34.00
HM187	Muffler 6HP	38.00
HM2612	Piston Pin 1 1/2-2HP & 3HP (Style "C")	18.50
HM2613	Piston Pin 3HP	20.50
HM2614	Piston Pin 6HP	30.25
HMR23	Piston Ring, 3 1/2" X 1/4" 1 1/2-2HP	6.00 ea.
HMR43	Piston Ring, 4 1/2" X 5/16" 3HP	8.00 ea.
HMR52	Piston Ring, 5 3/4" X 3/8" 6HP	14.00 ea.
HMR21	Piston Ring, 3 1/2" X 1/8" 1 1/2-2HP	6.00 ea.
HMR415	Piston Ring, 4 1/2" X 5/32" 3HP	8.00 ea.
HMR515	Piston Ring, 5 3/4" X 3/16" 6HP	14.00 ea.

**Check your rings - later engines had narrower widths.**

HM02	Sparkplug	5.00
HM159	Spring, Crankhandle Pawl 1 1/2-6HP	4.00
HM261A	Spring, Bosch AB-33 Trip Lever 1 1/2-6HP	6.00
HM2625	Spring, Governor Spindle Spring. 1 1/2-6HP	3.00
HM2626	Spring, Governor Weight Drag 1 1/2-6HP	4.50
HM263	Spring, Needle Valve 1 1/2-2HP	1.00
HM264	Spring, Needle Valve 3-6HP	1.25
HM265	Spring, Throttle Butterfly 1 1/2-2HP	4.95
HM266	Spring Throttle Butterfly 3-6HP	4.95
HM267	Spring, Intake Valve 1 1/2-2HP	4.75
HM188	Spring, Exhaust Valve 1 1/2-6HP	4.75
HM189	Spring, Intake Valve 3-6HP	4.75
HM1892	Spring, Intake Valve Drag 3-6HP	12.50
HM26855	Timer Assy, Battery Model Only 1 1/2-3HP	46.75

**(Timer Assy. includes timer plate, cover, 4 thin shims, 1 thick, & insulators)**

HM2686A	Timer Plate, Battery Model Only 1 1/2-3HP	3.00
HM2686B	Timer Cover, Battery Model Only 1 1/2-3HP	23.25
HM2686C	Timer Insulator Pack (Insulators & Bushings)	13.25
HM2686D	Timer Shim, (Battery Model Only), .018 Thick	1.50
HM2686E	Timer Shim, .042 Thick	1.50
HM269	Valve, Exhaust 1 1/2-2HP	31.50
HM190	Valve, Exhaust 3HP	35.25
HM191	Valve, Exhaust 6HP	40.25
HM270	Valve, Intake 1 1/2-2HP	31.50
HM271	Valve, Intake 3HP	35.25
HM272	Valve, Intake 6HP	40.25
HM273	Valve Keeper, Exhaust 1 1/2-2HP	7.25
HM2731	Valve Keeper, Exhaust 3-6HP	7.25
HM274	Valve Keeper, Intake 1 1/2-2HP	7.25
HM2741	Valve Keeper, Intake 3-6HP	7.25
HM275	Valve Clips 3/8" 1 1/2HP	1.00
HM2751	Valve Clips 7/16" 3-6HP	1.00

**(Usually requires 1 keeper and 1 clip per valve unless your valve has a hole instead of a groove. Please be specific when ordering.)**

**F/M STYLE "C" 3HP & F/M "52"**

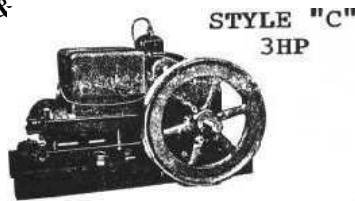

The style "C" has an enclosed crankcase with the mag mounted on the left side looking from the cyl. Head. The mags used on this model could have been an model "R", "RV", or "J" and the early "C's" used a base mounted mag with an enclosure plate covering the hole in the crankcase cover. Later "C's" or "S2's" used a flange mounted "J" mag that bolted directly to the crankcase cover. The "52" classification actually referred to the displacement of the piston rather than the HP. Parts listed here will fit the 3HP or "52" models.

L10	Instruction & Parts 3HP (Use for "52" also)	2.00
HM2781	Bearing, Main, Top Insert Only #23	20.00
HM207	Carb Air Valve Disc.	3.00
HM209	Carb Air Valve Plate	20.50
HM211	Carb Air Valve Compensating Spring	3.00
HM213	Carb Fuel Line Check Valve	4.50
HM216	Carb Needle Valve, Start Side (Long)	16.25

**F/M STYLE "C" 3HP cont.**

HM218	Carb Needle Valve, Fuel Side (Short)	16.25
HM220	Carb Needle Valve Seat, Start Side	18.50
HM222	Carb Needle Valve Seat, Fuel Side	19.25
HM224	Carb Needle Seat Clamp, Fuel Side Only	7.50
HM2783	Crankshaft Felt	2.00
HM27835	Crankshaft felt retainer (washer)	2.00
HM2675	Crankhandle, Complete (just like original)	71.50
HM225	Decal	4.00 ea.
HM2784	Exhaust Push Rod	15.75
HM233	Exhaust Push Rod End	19.00
HM2784B	Exhaust Rocker Lever	39.25
HM2785	Fuel Tank (for wood skids)	57.50
HM27852	Fuel Tank (for cast iron base)	55.00
HM2785B	Fuel Tank 6-7HP, "118"	67.50
HM239	Gasket, Air Valve Plate	1.50
HM241	Gasket, Butterfly Housing To Head	1.50
HM242	Gasket, Carb to Butterfly Housing	1.50
HM244	Gasket, Cylinder Head	8.50
HM2786	Gasket, Crankcase Cover	6.75
HM27863	Gov. Throttle Rod (to carb)	17.50
HM27865	Governor Assy. (Gear, weights, yoke & shaft, etc.)	178.50
HM27866	Governor Gear And Shaft, LH Threads	80.00
HM27867	Governor Spindle Rod	18.50
HM27868	Gov Throttle Push Rod (Vert. rod in cam/gov bracket)	4.50
HM2541	Governor Spindle Rod Adjusting Screw	9.50
HM2787	Governor Weight	16.25
HM2581	Governor Weight Pin	1.00
HM27873	Governor Yoke, LH Threads	47.00
HM2789	Magneto Gear (Steel)	99.00
HM2594	Magneto, Type "J", Base Plate	20.50
HM2595	Magneto, Type "J", Coil	68.00
HM2596	Magneto, Type "J", Coil & Points Cover	37.50
HM2597	Magneto, Type "J", Condensor	10.75
HM2598	Magneto, Type "J", Points Set	22.50
HM261	Muffler	27.50
HM2611	Oil Pan, Goes in bottom of crankcase	17.50
HMR25	Piston Ring 3 5/8" X 1/8" (Takes 2)	6.00 ea.
HMR26	Piston Ring, Oil 3 5/8" X 1/8" (Takes 1)	7.00
HM02	Sparkplug 1/2"NPT	5.00
HM01	Sparkplug 7/8", Later models used this size	5.00
HM263	Spring, Carb Needle	1.00
HM159	Spring, Crankhandle	4.00
HM2626	Spring, Governor Weight Drag	4.50
HM188	Spring, Exhaust Valve	4.75
HM267	Spring, Intake Valve	4.75
HM265	Spring, Throttle Butterfly	4.95
HM269	Valve, Exhaust	31.50
HM270	Valve, Intake	31.50
HM273	Valve Keeper, Exhaust	7.25
HM274	Valve Keeper, Intake	7.25
HM275	Valve Keeper Clip 3/8"	1.00

**FAIRBANKS MORSE STYLE "D" 1 1/2-2HP**

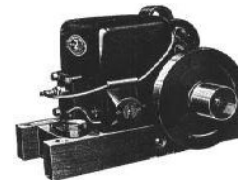

All "D's" basically look alike and the majority of the parts interchange between the 1 1/2HP and the 2HP. The two main differences are-(1) the cylinder bore and piston for the 1 1/2HP is 2 1/4" and the 2HP is 2 3/8", and (2) On the early 1 1/2HP model the governor yoke is smaller in diameter and the governor weights are narrower at the swivel point. The weights we list here are for the later 1 1/2HP's and the 2HP. If you have the early 1 1/2HP with a broken weight, we have a fix for it (call). The "D's" used the same base mounted mags as earlier Models (R, RV, & J). Although we have a good supply of used parts, the pot metal mixer and pulley are not always available. We would be interested in purchasing or trading for these items, either good used or repros.

**FAIRBANKS MORSE STYLE "D" 1½-2HP cont.**

L12	Instruction & Parts 1½HP	\$2.00
L13	Instruction & Parts 2HP	2.00
HM2793	Bearing, Camshaft, 1¼" Length	27.50
HM2794	Bearing, Crank & Camshaft, 1¼" length	27.50
HM2795	Bearing, Crankshaft, 2¼" length	27.50
<b>Good used bearings for sale \$15.00 ea. (2 halves)</b>		
HM207	Carb (Mixer) Air Valve Disc *	3.00
HM209	Carb Air Valve Cover Plate, Cast Iron *	18.50
HM211	Carb Air Valve Compensating Spring *	3.00

**\*Not original style-Above three parts will work in place of original metal stamped air valve assy. Originals sometimes available-call for price.**

HM218	Carb Needle Valve	16.25
HM2797	Con. Rod Oil Slinger	14.10
HM280	Crankhandle	24.50
HM225	Decal	4.00 ea.
HM281	Felt, Magneto Cover Plate	2.75
HM282	Felt Oil Seal With Hole	2.75
HM283	Felt Oil Seal Without Hole	2.75
HM213	Fuel Line Check Valve	4.50
HM284	Fuel Tank	55.50
HM285	Gasket, Air Valve Assy. To Carb	1.50
HM286	Gasket, Carb To Block	1.50
HM287	Gasket, Crankcase Cover (5 Pieces)	7.50
HM288	Gasket, Cylinder Head	6.50
HM2885	Governor Weight, Late style	16.25
HM2880	Magneto Gear (Fits "R, RV, or J") Steel	99.00

**Magneto parts for 'J' mag-see under 3HP model 'C' section.**

HM289	Muffler (Baffle plate-like the original)	8.50
HMR03	Piston Ring 2¼" X 1/8" 1½HP	5.00 ea.
HMR04	Piston Ring 2¼" X 1/8" 1½HP (Oil)	7.00
HMR05	Piston Ring 2 3/8" X 1/8" 2HP (Takes 3)	5.00 ea.
HMR06	Piston Ring 2 3/8" X 1/8" 2HP (Oil)	7.00
HM01	Sparkplug	5.00
HM2894	Spring, Governor (Goes Inside Camshaft)	4.00
HM263	Spring, Needle Valve	1.00
HM2896	Spring, Throttle Valve Spring	3.00
HM2897	Spring, Valve	3.00
HM290	Valve, Exhaust or Intake, late style	30.25

**FAIRBANKS MORSE ZC ENGINES**

**MODELS "118, 208,346, 503, 739"**

Early "C" style engines went by HP, 6-7HP, 9-10HP, etc. Again we point out the importance of giving us the diameter of your cylinder bore or piston when ordering parts.

*Hit & Miss is an authorized Arrow distributor for F/M engines and parts.*

We've been dealing in F/M "Z" parts almost 30 years and we're proud to include the Arrow line in our offering of F/M parts. We now have many parts (used and new) for "Z" engines from 1915 to present. We also offer expert magneto repair for all F/M engines. Check with us for all Arrow products, you'll like the way we deal here at Hit & Miss. This is only a partial listing of some of the more commonly asked for parts for the 118 & 208. For a quote on parts not listed here please call. Unfortunately not all parts for F/M engines are available, but if we can't help with new parts, we may be able to help from our inventory of good used parts.

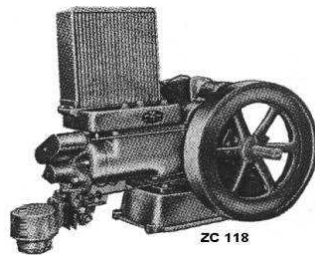

Model #	Bore & Stroke	HP	Speed
ZC-118	5 X 6	6-7	400-700
ZC-208	5¾ X 8	12	400-700
ZC-346	7 X 9	18	350-575
ZC-503	8 X 10	24	300-525
ZC-739	9¼ X 11	36	300-525

L11	Inst. & Parts 118, 208	\$9.50
L115	Inst. & Parts 346, 503, 739	\$9.50

**FAIRBANKS MORSE ZC ENGINES cont.**

\*Please email or call us for current prices

23-118	Bearing, Main, Old Style
23-A-118	Bearing, Main, New Style
23-208	Bearing, Main
A-126-118	Bearing Housing Shim .005
B-126-118	Bearing Housing Shim .007
C-126-118	Bearing Housing Shim .020
A-126-208	Bearing Housing Shim .005
B-126-208	Bearing Housing Shim .007
233-BC	Breather Valve Complete
128-A-118	Cam
28-A-118	Cam Gear W/Cam
30-B-118	Cam Gear Shaft, New Style
34-118	Cam Rocker Roller
35-118	Cam Rocker Roller Pin
18-AC-118	Conn. Rod Complete
18-AC-208	Conn. Rod Complete
5415-118	Conn. Rod Oil Thrower
5415-208	Conn. Rod Oil Thrower
A-110-118	Conn. Rod Shim .025
B-110-118	Conn. Rod Shim .007
C-110-118	Conn. Rod Shim .003
A-110-208	Conn. Rod Shim .025
B-110-208	Conn. Rod Shim .007
C-110-208	Conn. Rod Shim .003
176-A-118	Conn. Rod Bearing (Liner)
176-A-208	Conn. Rod Bearing (Liner)
29-118	Crankshaft Gear (Pinion) "old style"
29-208	Crankshaft Gear (Pinion) "old style"
9556-118	Crankshaft Oil Seal
9556-208	Crankshaft Oil Seal
3-BC-RK-118	Cyl. Head Repair Kit
3-BC-RK-208	Cyl. Head Repair Kit
298-118	Dial Oil Lever Gauge
36-C-118	Exhaust Push Rod Complete
36-C-208	Exhaust Push Rod Complete
10-118	Exhaust Valve
10-208	Exhaust Valve
287-118	Exhaust Valve Guide
87-118	Exhaust Valve Seat
87-208	Exhaust Valve Seat
317-118	Exhaust Valve Spring
317-208	Exhaust Valve Spring
11-118	Exhaust Valve Spring Collar
A-122-118	Exhaust Valve Collar Lock
1141-A-118	Fan Assembly
1141-A-208	Fan Assembly
7806-LD-118	Fan Blade Assy.
1145-118	Fan Belt
1145-208	Fan Belt
1142-118	Fan Support
157-118	Flywheel Key
157-208	Flywheel Key
1119-208	Gasket, Hand Hole Cover (Old Style) 208
1119-A-208	Gasket, Hand Hold Cover (New Style) 208
190-118	Gasket, Cyl. Head (Copper Clad) 118
190-208	Gasket, Cyl. Head (Copper Clad) 208
191-118	Gasket, Water Hopper 118
191-208	Gasket, Water Hopper 208
1286-118	Gasket, Crankcase Cover 118
1286-208	Gasket, Crankcase Cover 208
1892-118	Gasket, Base End Cover Gasket 118, 208
1898-118	Gasket, Bearing Housing, Gov side 118
1898-208	Gasket, Bearing Housing, Gov side 208
1899-118	Gasket, Bearing Housing, Opp Side 118
1899-208	Gasket, Bearing Housing, Opp Side 208
2025-118	Gasket, Mag Gear Closure 118, 208
237-118	Gasket, Fuel Mixer Cover 118, 208
2340-118	Gasket, Governor Cover 118, 208
247-118	Gasket, Air Valve 118, 208

**FAIRBANKS MORSE ZC ENGINES cont.**

249-118	Gasket, Carb 118, 208
407-118	Gasket, Cyl Cover Bolt 118, 208
4910-118	Gasket, Magneto Head Gasket 118, 208
5914-118	Gasket, Breather Valve Seat 118, 208
6147-118	Gasket, Radiator Core 118
6147-208	Gasket, Radiator Core 208
A-990-118	Gasket, Oil Gauge (old style) 118, 208
ACE-415-46	Gasket, Oil Gauge Base 118, 208
ACE-409-46NS	Gasket, Oil Gauge 118, 208
C-749-C-118	Gasket Set, Complete for 118
C-749-C-208	Gasket Set, Complete for 208
33-118	Governor Drag Spring
81-118	Governor Head (Yoke)
48-118	Governor Pinion (Gear) & Shaft
205-C-118	Governor Pull Rod Complete
205-C-208	Governor Pull Rod Complete
308-118	Governor Spring
82-118	Governor Weight
6-RS-118	Piston Ring Set-Standard
6-RS-208	Piston Ring Set-Standard

**(Oversize Rings Available)**

B-5-118	Piston
7-118	Piston Pin
7-208	Piston Pin
17-118	Piston Pin Bushing
17-208	Piston Pin Bushing
130-118	Radiator Drain Cock 1/8-27
39-118	Rocker Arm
40-118	Rocker Arm Pin W/Zert
41-208	Rocker Arm Bracket
HM01A	Sparkplug, Long Reach
9-B-118	Suction Valve
9-B-208	Suction Valve
310-118	Suction Valve Spring
120-118	Suction Valve Drag Spring
617-118	Suction Valve Bumper Spring
121-B-118	Suction Valve Spring Collar
B-122-B	Suction Valve Lock Nut
288-118	Suction Valve Guide
87-118	Suction Valve Seat
87-208	Suction Valve Seat

**FULLER JOHNSON models "NC", "ND", "NK"  
1 1/2-2 1/4 HP**

**Solid flywheels, WICO 'EK' magneto, hit & miss governor. We do have a few used parts for these models from time to time.**

L21	Instruction & Parts "NC" 1 1/2-2 1/2HP	1.50
LS61	Instruction & Parts "ND"	1.50
HM3002	Bearing, Rod 2HP	29.95
HM3004	Carb Needle Valve 1 1/2-2 1/2HP	15.75
HM3005	Carb Needle Valve Seat 1 1/2-2 1/2HP	15.75
HM3006	Decal, All Engines	6.00 ea.
HM3007	Exhaust Lever 2-2 1/2HP	35.50
HM30075	Fuel Tank, 2HP "NC" (With bushing & hanger)	72.50
HM3008	Governor Weight & Rod 1 1/2-2 1/4HP "NC"	32.50
HM392	Muffler (Please give pipe size)	42.50
HM3095	Nameplate	12.00
HM01	Sparkplug	4.50
HM301	Valve, Intake or Exhaust Same, 1 1/2-2 1/2HP	28.50

Hit & Miss Ent.

Customer Appreciation Show & Swap

June 3 & 4, 2011

**June 1 & 2, 2012**

Free admission, free camping (no hook-ups),

Prizes, Demo's, Buy & Sell (no charge)

**FULLER JOHNSON ENGINES-MISC MODELS**

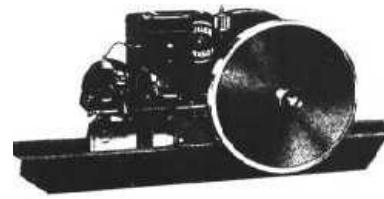

**This section is for owner's of other models of Fuller Johnson engines including the "Farm Pump Engines". Although parts are scarce it may pay to check with us as we never know what might come in. Here is a list of some literature and a few new parts. Some items from this section and the "ring list" may help you.**

L225	Instruction & Parts "Type N" 3-12HP	4.00
LS58	Sales Brochure "NB" 1 1/2 -12HP	1.50
L22	Instruction & Parts "Farm Pump Engine" 1927	3.00
LS63	Parts Only, "Farm Pump Engine" 1933	1.50
LS57	Advertising Brochure, "N" 1 1/2-10HP	4.00
LS59	Inst. & Parts "NB" 3HP 1926	2.00
LS62	Advertising Catalog #17A, "Pump Engine" 1922	9.50
LS60	Adv. #506, Pump Engine With Diaphragm Pump	1.00
LS64	Adv. #307, Pump Engine With Pressure Pump	1.00
LS642	Adv. #605, Pump Engine With Force Pump	1.00
HM3011	Bearing, Rod, "Farm Pump Engine"	31.50
HM30112	Ex. Lever, "Farm Pump Engine"	46.75
HM30114	Ex. Lever Bracket, "Farm Pump Engine"	51.25
HM3012	Fuel Tank, "Farm Pump Engine"	59.50
HM3013	Muffler, Pump Engine 1/2" or 3/4" (Please give size)	52.50
HMR23	Piston Ring, Pump Engine, 3 1/2" X 1/4"	6.00
HM3015	Spring, Ignitor Tension "N"	6.00
HM3015A	Spring, Ignitor Torsion "N"	6.00
HM3017	Valve, "NB" 3HP, Exhaust	31.50
HM3017A	Valve, "NB" 3HP, Intake	31.50
HM3019	Valve, Exhaust or Intake, Pump Engine	30.25

**GALLOWAY**

L23	Instruction & Parts 1 3/4-2 1/4 HP	4.50
L24	Instruction & Parts 5, 7, 9, 12 & 16HP	4.50
M20	Bearing, Rod 1 3/4-2 1/4 HP	31.50
M23	Bearing, Rod 3HP (1 5/8" shaft)	35.75
M27	Bearing, Rod 4-7HP? (2" shaft)	46.75
M30	Carb Needle Valve 1 3/4-2 1/4 HP	16.25
M34	Decal, 1 3/4" X 5 1/4"	6.00
M35	Decal, 2" X 5" (Script)	6.00
M36	Decal, 3 1/2" X 10 1/2"	7.00
M40	Exhaust Lever 1 3/4-2 1/4 HP	40.25
M43	Exhaust Lever 5-7HP	48.50
M45	Muffler 1 3/4-2 1/4 HP	46.75
M47	Nameplate, All Engines (Before 1911)	13.25
M47A	Nameplate, All Engines (After 1911)	13.25
M50	Spring, Ignitor 1 3/4-10HP	6.00
M52	Valve, Exhaust, 1 3/4-2 1/4 HP	31.50
M52A	Valve, Intake, 1 3/4-2 1/4 HP	31.50
M53	Valve, Exhaust, 3-4HP	35.75
M53A	Valve, Intake 3-4HP	37.75

**HERCULES 1 1/2-12HP (Economy-Jaeger-etc.)**

**-and others. We can't guess how many jobber's sold Hercules engines, but the above were the most popular. The models we're referring to in this section are the "D,E,F,G,H,&S". Some of these parts will fit the not so common "N" and we list parts for the "JK-XK" in a separate listing. We do not have a listing for Thermoil. When ordering parts for Hercules please give the HP and the letter with it off the serial tag on the top of the engine (Jaeger engines have an extra plate on the lower side of the block-do not use info off of this tag for ordering). Here are some other notes that may be helpful to you.**

**No Serial Plate?** Give us the diameter of piston and we'll ask you a few questions to determine HP, etc.

**1 1/2-2HP Cyl. blocks and caps** have a double liner for main bearing, one is a factory installed poured liner, not replaceable, must be poured. The replaceable insert sets in this (APPLYS ONLY TO 1 1/2-2HP engines).

**HERCULES 1½-12HP cont.**

**Throttle Governed or Hit & Miss**-Most parts interchange except head, carb & related parts, and some gov. pieces. Let us know if you have T/G style. WICO or Webster Mag or nothing? The models this parts list pertains to will take either set-up. If you are missing everything we'll help you determine what is correct for your model and what your options are if it's not available, un-affordable, etc. **History of Hercules** by Glen Karch 1914-1934 this 20 year period is when most of the engines in collector's hands were made. Although this book is on Hercules engines it is good reading for anyone.

L25	Instruction & Parts 1½ -12HP, 64 pages	9.00
L270	History of Hercules by Glen Karch	10.00
L271	Serial # List	1.00
L076	Instruction & Parts, Economy 1½-12HP, 1926	4.00
HM302	Bearing, Rod 1½-2HP	22.75
HM3021	Bearing, Rod (Cyl. Bore 3 5/8") 2-2½HP	31.50
HM3022	Bearing, Rod 2½-3½HP	35.75
HM3023	Bearing, Rod 5-6HP	46.50
HM3024	Bearing, Rod 7-8HP	58.00
HM3025	Bearing, Rod 9HP	65.75
HM3026	Bearing, Rod 12HP	138.25
HM303	Bearing, Main 1½-2HP	27.75
HM3031	Bearing, Main (Cyl. Bore 3 5/8") 2-2½HP	35.25
HM3032	Bearing, Main 2½-3½HP	39.10
HM3033	Bearing, Main 5-6HP	59.75
HM3034	Bearing, Main 7HP	72.25
HM3035	Bearing, Main 9HP	95.00
HM30355	Bearing, Main 12HP	182.00
HM305	Carb Choke Plate 1½-2HP	11.75
HM306	Carb Choke Plate 2½-3½HP	12.25
HM307	Carb Choke Plate 5-6HP	13.25
HM309	Carb Needle Valve 1½-12HP	18.50
HM310	Carb Needle Flat Spring (held on with screw)	7.00
HM311	Carb Needle Valve Wire Spring (goes in hole)	1.00

**(Following carb parts are for kerosene. pump type carbs.)**

HM3036	Carb Drain Valve	19.25
HM308	Carb Fill Hole Lid	11.75
HM3037	Carb Fuel Needle Valve	18.50
HM3038	Carb Pump Body	91.25
HM3039	Carb Pump Plunger	33.75

**For related parts see "Fuel Line Assy.", etc.**

HM431	Carb Throttle Water Valve Assembly	53.10
HM315	Con. Rod Bushing 1½-2HP	12.25
HM3151	Con. Rod Bushing (3-5/8" Bore) 2-2½HP	13.25
HM316	Con. Rod Bushing 2½-3½HP	16.75
HM317	Con. Rod Bushing 5-6HP	19.25
HM3171	Con. Rod Bushing 7HP	24.50
HM318	Crankguard 1½-2HP	52.50
HM320	Crankhandle 1½-2HP *Closed style	44.75
HM3205	Decal, ARCO	6.00 ea.
HM321	Decal, Economy 1-5/8"x 6"	3.00 ea.
HM322	Decal, Economy 3¾"x 10"	7.00 ea.
HM323	Decal, Economy "Propeller" 2-1/8"x 6½"	7.50 ea.
HM325	Decal, Hercules Engine	6.00 ea.
HM327	Decal, Jaeger	8.00 ea.



HM329	Exhaust Rocker Lever 1½ HP **Model "N" Only	46.75
HM330	Ex Rocker Lever 1½-2HP	31.50
HM3305	Ex Rocker Lever 2-2½ HP "S" **With 3 5/8" Bore	46.75
HM331	Ex Rocker Lever 2½ -3½ HP	38.50
HM332	Ex Rocker Lever 5-6HP	40.25
HM3325	Ex Rocker Lever 7-8HP	58.00
HM333	Ex Rocker Lever Adj. Bolt (like original)	8.25
HM334	Exhaust Push Rod Assy. 1½-2HP	94.25
HM3345	Exhaust Push Rod Assy. 2HP "H", 2½ HP "S"	94.25
HM335	Exhaust Push Rod Only 1½-2HP	40.25
HM336	Exhaust Push Rod Cam Roller 1½-2½ HP "S"	15.50

**HERCULES 1½-12HP cont.**

HM3361	Exhaust Push Rod Cam Roller 2½-12HP	15.75
HM337	Exhaust Push Rod Cam Roller Pin Only 1½-2½ HP "S"	15.00
HM3371	Exhaust Push Rod Cam Roller Pin Only 2½-12HP	10.00
HM338	Exhaust Push Rod Detente Latch Block 1½-2½ HP "S"	24.50
HM3382	Exhaust Push Rod Detente Latch Block 2½-12HP	24.50
HM339	Flywheel Key, Straight 1½-2HP	1.25
HM3391	Flywheel Key, Straight 2-2½HP	1.25
HM3392	Flywheel Key, Straight 2½-3½HP	1.25
HM3393	Flywheel Key, Straight 5-6HP	1.75
HM3394	Flywheel Key, Straight 7-8HP	1.75

**Flywheels with split hubs do not require tapered keys.**

HM340	Fuel Line Assy. (From tank to carb)	23.25
HM3405	Fuel Line Check Valve (included with HM340)	15.75
HM3511	Fuel Pipe "T" (included with HM340)	2.00
HM343	Fuel Tank, Fills Mag Side 1½-2HP	52.50
HM344	Fuel Tank, Fills Opposite Side 1½-2HP	52.50
HM3435	Fuel Tank- fills in back 2HP "H & ?"	52.50



**"H" tank may be special ordered with fill in front.**

HM345	Fuel Tank, Fills Mag Side 2½-3½ HP	57.50
HM346	Fuel Tank, Fills Opposite Side 2½-3½HP	57.50
HM347	Fuel Tank, Fills Mag Side 5-6HP	67.50
HM348	Fuel Tank, Fills Opposite Side 5-6HP	67.50
HM3485	Fuel Tank, Fills Mag Side 7-8HP	74.00
HM3486	Fuel Tank, Fills Opposite Side 7-8HP	74.00
HM349	Fuel Tank Filler Spout W/Lid 1½-5HP	41.25
HM350	Fuel Tank Filler Lid 1½-2HP, (hinged type)	5.00
HM351	Fuel Tank Lid, Swivel 1 5/8" dia.	5.00
HM3512	Fuel Filler Lid, Swivel 2 5/8" dia.	5.00
HM352	Gasket, Cyl. Head 1½-2HP	8.50
HM353	Gasket, Cyl. Head 2-2½HP (3-5/8")	8.50
HM354	Gasket, Cyl. Head 2½-3½HP	9.50
HM355	Gasket, Cyl. Head 5-6HP	11.50
HM356	Gasket, Cyl. Head 7-8HP	13.50
HM357	Gasket, Mag Bracket 1½-2½HP "S"	3.00
HM358	Gasket, Mag Bracket 2½-12HP	3.00
HM3585	Gear, Cam 1½-2 HP	159.50
HM3586	Gear, Cam 2½ "E"-6HP	182.00
HM3587	Gear, Cam 7-8HP	203.75
HM359	Gear, Crankshaft Pinion 1½ - 2HP	80.50
HM3592	Gear, Crankshaft Pinion 2½ "E"- 3½ HP	94.25
HM3594	Gear, Crankshaft Pinion 5-6HP	94.25
HM3596	Gear, Crankshaft Pinion 7-8HP	127.00

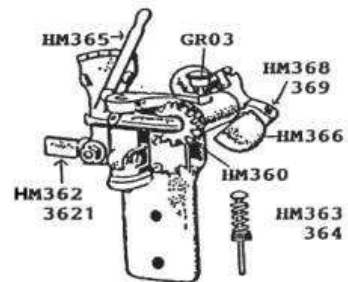

HM360	Gear Gov. Pinion 1½-12HP	46.75
HM362	Gov. Detente Blade 1½-2HP	27.00
HM3621	Gov. Détente Blade 2 ½-12HP (1 bolt hole)	32.25
HM3621A	Gov. Detente Blade 2½-12HP (2 bolt hole)	32.25
HM3621B	Gov. Détente Blade Bolt 1½-12HP	12.75
HM3621C	Gov. Détente Blade Adjusting Screw	12.75
HM3622	Gov. Détente Lever 1½-2HP	39.75
HM3624	Gov. Détente Lever 2½-12HP	39.75
HM363	Gov. Spindle Rod 1½-2HP	18.50
HM3632	Gov. Spindle Rod 2HP "H"-2½HP "S"	18.50
HM364	Gov. Spindle Rod 2½-12HP	19.25
HM3642	Gov. Yolk/spindle shaft 1 1/2-2HP	94.25
HM3645	Gov. Bracket 1½-2HP (¾" cyl. bore models)	85.50
HM365	Gov. Speed Control Lever 1½-12HP	8.25
HM366	Gov. Weight 1½-2½HP	16.75
HM3662	Gov. Weight 2½-12HP (round style-early)	29.25
HM368	Gov. Weight Pin 1½-2½HP "S"	1.75

**HERCULES 1½-12HP cont.**

HM369	Gov. Weight Pin (for early style weight) 2½-12HP	3.00
HM371	Grease Cup, Auto Brass 1½-2HP "S"	52.50
HM372	Grease Cup, Auto Brass 2½-12HP	62.50
GR03	Grease Cup, Rod 1½-2½HP	7.50
GR04	Grease Cup, Main 1½-2½HP	9.50
GR05	Grease Cup, Rod 2½-12HP	11.00
GR07	Grease Cup, Main 2½-12HP	15.00

**WICO EK Related Parts.**

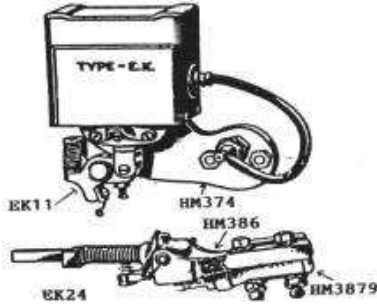

HM374	Mag Bracket 1½-2½HP "S"	53.10
HM375	Mag Bracket 2½-12HP	55.75
EK11	Trip Rocker (EK will work with PR)	29.50
EK14	Armature Return Spring (EK)	4.00
EK18	Trip Finger Mag Drive Spring	4.00
EK22	Armature Spring Support (EK)	10.00
EK23	Armature Spring Support Shaft & Nut	14.50
EK24	Trip Finger Assy. 1½-12HP (EK)	65.10
EK25	Trip Finger Latch Group Only	25.00
EK26	Trip Finger Frame Group Only	35.75
EK27	Trip Finger Retard Lever	4.50
HM386	Trip Finger Bracket 1½-2½HP "S"	35.75
HM387	Trip Finger Bracket 2½-12HP	31.10
HM3879	Push Rod Clamp 1½-2½HP	33.75
HM388	Push Rod Clamp 2½-12HP	39.75

**Webster Related Parts.**

WEB11	Mag. Trip Finger Assy. 1½-12HP	58.00
-------	--------------------------------	-------

See "Webster Magneto" section in "The Electrical Connection"

HM393	Muffler, Ball 7" Dia. 1" To 1½"NPT (Give NPT)	52.50
HM394	Muffler, Ball 9" Dia. 2" To 2½"NPT (Give NPT)	99.75
HM395	Muffler, Cone 6" Dia. 1" To 1¼"NPT (Give NPT)	52.50

**Nice casting with square head nuts and bolts.**

HM396	Nameplate 1½-12HP	8.00
-------	-------------------	------

**Oilers - see "Engine Accessories" section.**

HM3965	Piston 1½-2HP (3¼" Bore)	162.50
HM397	Piston Wrist Pin 1½-2HP	16.25
HM3975	Piston Wrist Pin (3 5/8-Piston) 2 "H"-2½ "S" HP	16.75
HM398	Piston Wrist Pin 2½-3½HP	18.50
HM399	Piston Wrist Pin 5-6HP	23.75
HM3991	Piston Wrist Pin 7-8HP	26.75

**\*Before ordering piston rings please check your cylinder bore.**

HMR20	Piston Ring, 3¼" x¼" 1½-2HP	6.00 ea.
HMR28	Piston Ring, 3 5/8" x¼" 2-2½HP	6.00 ea.
HMR35	Piston Ring, 4" x 5/16" "E" 2½HP	8.00 ea.
HMR39	Piston Ring, 4¼" x 5/16" 3-3½HP	8.00 ea.
HMR48	Piston Ring, 5" x 3/8" 5-6HP	12.00 ea.
HMR52	Piston Ring, 5¾" x 3/8" 7-8HP	14.00 ea.
HM401	Pulley With Keyway & Set Screw for 1¼" Shaft	83.10

**(For shafts to 1½" see "Pulleys" section.)**

HM02	Sparkplug	4.50
HM406	Spring, Ex. Valve 1½-2HP	4.75
HM407	Spring, Ex. Valve 2½-6HP	4.75
HM4075	Spring, Ex. Valve 7-8HP	6.50
HM4015	Spring, Detent 1½-12HP	2.50
HM402	Spring, Ex. Push Rod 1½-2½HP "S"	4.75
HM403	Spring, Ex. Push Rod 2½-8HP	5.00
HM404	Spring, Gov. Spindle Rod 1½-2HP	3.50
HM405	Spring, Gov. Spindle Rod 2½-12HP	3.50

**HERCULES 1½-12HP cont.**

HM408	Spring, Intake Valve 1½-2HP	4.75
HM409	Spring, Intake Valve 2½-6HP	4.75
HM4095	Spring, Intake Valve 7-8HP	6.50
HM4097	Spring, Valve Lock 2 1/2-6HP	4.00
HM4097A	Spring, Valve Lock 7-12HP	4.00
HM415	Valve, Exhaust Or Intake 1½-2HP	31.50
HM4155	Valve, Ex. or In. (3 5/8" Cyl. Bore) 2-2½HP	31.50
HM416	Valve, Ex. or In. 2½-3½HP	33.75
HM417	Valve, Ex. or In. 5-6HP	39.75
HM418	Valve, Ex. or In. 7-8HP	46.75
HM4183	Valve, Ex. or In. 9HP	53.10
HM4185	Valve, Ex. or In. 12HP	59.75
HM4192	Valve Lock, 2½-3½HP	13.25
HM4193	Valve Lock, 5-6HP	13.25
HM4194	Valve Lock, 7-8HP	13.25
HM4195	Valve Lock, 9-10HP	13.25
HM4197	Valve Lock Stud 2½E-6HP	5.00
HM4197A	Valve Lock Stud 7-12HP	5.00

**HERCULES OR ECONOMY "XI" & "XK" 1¼-8HP**

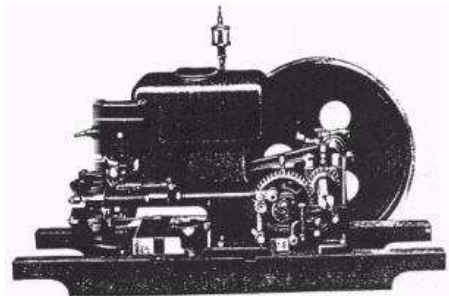

These engines showed up in 1928. One outstanding feature is the flywheels are solid with three round holes. The "XI" is a gasoline only hit & miss engine, while the "XK" is gasoline or kerosene and throttle governed. Other than the flywheels the 6 & 8HP models are the same as the earlier 5 & 7HP models and you may use the preceding list for Hercules to order parts for these sizes only. We have various used parts available for these engines as well.

L251	Instructions & Parts, 51 pages, 1¼-8HP	8.50
L26	Parts Only, Good Illustrations	6.00
LS68	Price List, 1929, "XI-XK" 1¼-8HP	1.00
HM302	Bearing, Rod 1¼HP	22.75
HM303	Bearing, Main 1¼HP	27.75
HM3405	Carb, Fuel Line Check Valve 1¼-4HP	15.75

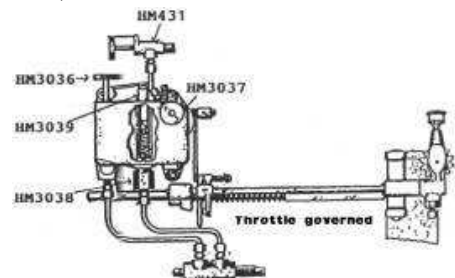

HM425	Carb, Needle Valve Fuel (Short) 1¼-3HP	18.50
HM426	Carb, Needle Valve Start (Long) 1¼-3HP	18.50
HM310	Carb, Needle Valve Flat Spring 1¼-4HP	7.00

**The following carb parts are for 6-8 pump type carb.**

HM3036	Carb Drain Valve, 6-8HP	19.25
HM308	Carb Fill Hole Lid	11.75
HM3037	Carb Fuel Needle Valve	18.50
HM3038	Carb Pump Body	91.25
HM3039	Carb Pump Plunger	33.75
HM431	Carb Throttle Water Valve Assembly	52.50
HM315	Connecting Rod Bushing 1¼HP	12.75
HM4262	Exhaust Push Rod Cam Roller	15.75
HM4263	Exhaust Push Rod Cam Roller Pin	19.25
HM347	Fuel Tank, Fills Mag Side, 6HP	67.50
HM348	Fuel Tank, Fills Opposite Side, 6HP	67.50

**HERCULES OR ECONOMY "XP" & "XK" 1 3/4-8HP cont.**

HM4271	Gasket, Carb 1 3/4-3HP	3.00
HM4272	Gasket, Head 1 3/4HP	8.50
HM4273	Gasket, Head 2-3HP	9.50
HM4275	Governor Throttle Rod 1 3/4 "XK"	26.00
HM360	Governor Gear	46.75
HM361	Gov. Control Lever 1 3/4-4HP	42.25
HM4278	Gov. Shaft Spindle Rod	19.25
HM428	Gov. Weight	31.50
GR03	Grease Cup (Rod) 1 3/4HP	7.50
GR04	Grease Cup (Main) 1 3/4HP	9.50
HM395	Muffler Cone 6" (Give H.P. When Ordering)	52.50
HM3965	Piston (3 1/4" Bore), "Wristpin not included"	162.50

**(Oversize piston available)**

HMR20	Piston Ring, 3/4" x 1/4", 1 3/4HP	6.00 ea.
HM397	Piston Wrist Pin	16.25
HM02	Sparkplug	5.00
HM402	Spring, Exhaust Push Rod 1 3/4HP	4.75
HM403	Spring, Exhaust Push Rod 6-8HP	5.00
HM406	Spring, Exhaust Valve 1 3/4-4HP	4.75
HM407	Spring, Exhaust Valve 6HP	4.75
HM4075	Spring, Exhaust Valve 8HP	6.50
HM408	Spring, Intake Valve 1 3/4HP	4.75
HM409	Spring, Intake Valve 6HP	4.75
HM4095	Spring, Intake Valve 8HP	6.50
HM4295	Valve, Exhaust Or Intake 1 3/4HP	31.50
HM4296	Valve, Exhaust Or Intake 2 1/2-3 1/2HP	33.75
HM417	Valve, Exhaust Or Intake 6HP	39.25

**HERCULES-ECONOMY "JP" & "JK" 1 1/2 & 2 1/2 HP**

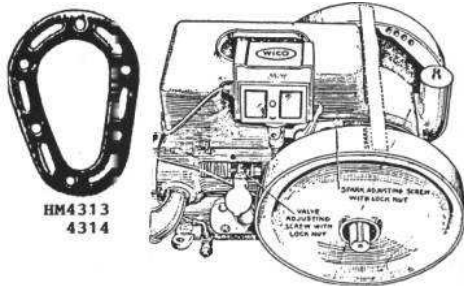

L265	Instructions & Parts, "JK" 1 1/2 -2HP	3.50
L266	Instructions & Parts, "JK" 2 1/2-3 1/2HP	3.50
L27	Parts List, Good Illustrations 1 1/2-3 1/2HP	3.50
HM302	Bearing, Rod 1 1/2-2HP	22.75
HM4302	Bearing, Rod 2 1/2-3 1/2HP	31.50
HM3405	Carb Fuel Line Check Valve	15.75
HM425	Carb Needle Valve Short, "JK"	18.50
HM426	Carb Needle Valve Long, "JK"	18.50
HM310	Carb Needle Valve Flat Spring	7.00
HM315	Connecting Rod Bushing 1 1/2-2HP	12.75
HM320	Crankhandle 1 1/2-2HP (2 1/2-3 1/2 available)	40.50
HM4311	Gasket, Carb 1 1/2-2HP	2.25
HM4312	Gasket, Carb 2 1/2-3 1/2HP	2.25
HM4313	Gasket, Head 1 1/2-2HP	9.00
HM4314	Gasket, Head 2 1/2-3 1/2HP	10.50
HM395	Muffler (Give HP When Ordering)	52.50
HMR18	Piston Ring, 3 1/4" X 3/16", 1 1/2-2HP	6.00 ea.
HM02	Sparkplug	4.50
HM4331	Valve, Exhaust 1 1/2-2HP	31.50
HM4332	Valve, Intake 1 1/2-2HP	31.50
HM4333	Valve Guide, Exhaust 1 1/2-2HP	29.25

**IDEAL "AIR COOLED"**

L28	Instructions & Parts, Rectangular C/C Cover	4.00
L280	Instructions & Parts, Round C/C Cover	4.00
HM4337	Gov. speeder Latch X81, 1 1/2HP	18.50
HM4338	Gov. Weight, 3/4HP	44.75
HM434	Gov. Weight, 1 1/2HP	44.75
HM4342	Gov. Weight Throw out Spring & Adj. Screw (All HP)	18.50
HM4347	Detent Lever Assy., 3/4HP	78.00

**IDEAL cont.**

HM435	Detente Lever, 1 HP	78.00
HM436	Detente Lever, 1 1/2HP	78.00
HM4366	Timer Block Assembly	25.00
HM437	Valve-Exhaust or Intake 1HP, 11" flywheels	29.25
HM4375	Valve-Exhaust or Intake 1 1/2HP, 12 1/2" flywheels	29.75
HM4385	Valve Plug, Exhaust (brass-all HP)	44.75
HM4386	Valve Plug, Intake (brass-all HP)	44.75
HM4387	Valve Plug Tool	9.50

**IHC-MCCORMICK-DEERING MODEL "M" 1 1/2-6HP**

For the money possibly the best engine built for it's time (1917-1937), well constructed and when right, every one starts exactly the same (even the 10HP) and runs like a clock. All "M"s are throttle governed and basically look the same. The 3 & 6HP had no major design changes, but did change the cylinder head and block casting to

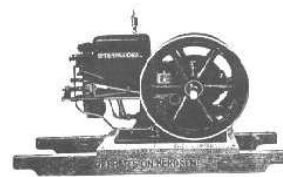

accommodate the ignitor or sparkplug ignition system. The early engines had ignitors (to 1921), then a switch to sparkplug with a rotary Bosch mag, and in 1924 WICO "EK" magnetos were introduced. The 1-1/2HP ignition system, etc. changed the same as the larger sizes, but there was an additional change with the 1-1/2HP when IHC switched from Bosch to WICO EK mags. The cylinder block had a larger bore (3-5/8" compared to the smaller bore of 3-1/4" for the earlier blocks). Please remember there can be exceptions to anything. We have the experience to help you order the correct parts for your 'M'.

L33	Inst. & Parts 1 1/2-6HP, Ignitor Model	6.00
L31	Inst. & Parts 1 1/2-6HP, Sparkplug Model	7.00
L32	Shop Manual 1 1/2-6HP, Sparkplug Model.	9.50
HM4501	Bearing, Rod 1 1/2HP	35.25
HM4502	Bearing, Rod 3HP	39.10
HM4503	Bearing, Rod 6HP	52.50
HM450310	Bearing, Rod 10HP	102.25
HM4504	Bearing, Main 1 1/2HP	39.75
HM4505	Bearing, Main 3HP	46.75
HM4506	Bearing, Main 6HP	75.00
HM450610	Bearing, Main 10HP	168.00
HM4507	Bushing, Con Rod 1 1/2HP	27.00
HM4508	Bushing, Con Rod 3HP	27.00
HM4509	Bushing, Con Rod, 6HP	29.25



**IHC "M" 1 1/2 gasoline carb**

HM451	Carb Choke Plate 1 1/2HP	5.00
HM452	Carb Choke Plate 3HP	5.00
HM453	Carb Choke Plate 6HP	5.00
HM454	Carb Compensating Valve 1 1/2HP	16.10
HM455	Carb Compensating Valve 3HP	16.75
HM456	Carb Compensating Valve 6HP	18.50
HM457	Carb Comp. Valve Stud & Nut 1 1/2HP	6.25
HM458	Carb Comp. Valve Stud & Nut 3HP	6.25
HM459	Carb Comp. Valve Stud & Nut 6HP	6.25
HM460	Carb Back Round Cover 1 1/2HP	7.25
HM461	Carb Back Round Cover 3HP	7.50
HM4610	Carb Back Round Cover 6HP	8.25

**IHC "M" 10HP Bearings, valves, all carb parts & piston rings now available. Please call or email for prices. Also cyl head, carb, ignitor & magneto rebuilding service available.**

**IHC-MCCORMICK-DEERING MODEL "M" 1½-6HP cont.**

HM46101	Carb Body 3-Way Valve (Early) 1½HP	58.00
HM46102	Carb Body 3-Way Valve (Early) 3HP	60.75
HM46103	Carb Body 3-Way Valve (Early) 6HP	69.00
HM46104	Carb 3-Way Valve Holddown (Flat Spring)	14.10
HM46105	Carb Draincock 1/8", Brass	6.75
HM46107	Carb Drain Plug, 1/4" NPT	.35
HM4613	Carb Filler Plug, Round-Brass 1½-3HP	12.75
HM4614	Carb Filler Plug, Round-Plain 1½-3HP	11.25
HM46142	Carb Filler Plug, Round 6HP	11.25
HM4615	Carb Filler Plug, Half-Round 1½-3HP	5.10
HM4616	Carb Filler Plug, Rectangular 1½-3HP	16.10
HM46162	Carb Filler Plug, Rectangular 6HP	18.50
HM4617	Carb Filler Plug, 3/8" NPT	3.00
HM4618	Carb Filler Plug Chain 1 FT.	3.00
HM4619	Carb Filler Plug Chain S-Hook	.75
HM462	Carb Fuel Line Elbow 1/4 NPT- 3/8" Tube	2.50
HM4623	Carb Fuel Line Conn 1/4"NPT- 3/8" Tube	1.25
HM464	Carb Needle Valve 1½-3HP (1 or 3 needle carb)	18.50
HM4645	Carb Needle Valve 1½HP (2 needle carb only)	20.00
HM465	Carb Needle Valve 6HP (3 needle carb only)	20.00
HM4655	Carb Needle Valve 3-6HP (2 needle carb only)	20.50
HM466	Carb Needle Valve Siphon Seat 1½-3HP	14.25
HM467	Carb Needle Valve Siphon Seat 6HP	16.10
HM468	Carb Needle Valve Siphon Nut 1½-3HP	6.25
HM469	Carb Needle Valve Siphon Nut 6HP	7.00
HM4698	Carb Needle Pointer Plate, Gas Carb Only 1½HP	10.00
HM470	Carb Needle Pointer (2 or 3 Pts.) 1½-3HP	10.00
HM471	Carb Needle Pointer (2 or 3 Pts.) 6HP	10.25
HM472	Carb Water Pressure Valve (Give HP)	46.75

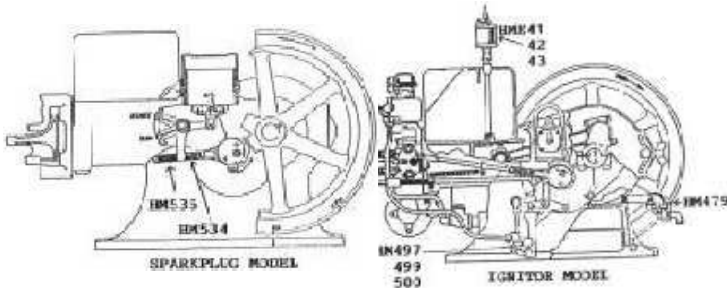

HM473	Carb Venturi Sleeve 1½HP	2.75
HM474	Carb Venturi Sleeve 3HP	2.75
HM475	Carb Venturi Sleeve 6HP	2.75
HM479	Crankcase Breather Valve 1½-6HP	65.00
HM4795	Crankshaft Grease Cup, L/H Threads 1½-6HP *	
* Discontinued-Looking for a supplier. At times originals are available.		
HM4797	Crankshaft Keyguard	30.25
HM4799	Cylinder Sleeve "O" Ring 1½HP, 3¼" bore	6.75
HM480	Cylinder Sleeve "O" Ring 1½HP, 3 5/8" bore	6.75
HM4801	Cylinder Sleeve "O" Ring 3HP	7.25
HM4802	Cylinder Sleeve "O" Ring 6HP	7.25



HM485	Decal, McCormick-Deering 1½-3HP	3.50 ea.
HM486	Decal, McCormick-Deering 6HP	6.50 ea.
HM4865	Decal, International 1 1/2-3HP	5.00ea.
HM487	Decal, IHC Double Globe 1½HP	3.50 ea.
HM488	Decal, IHC Double Globe 3HP	5.00 ea.
HM489	Decal, IHC Double Globe 6HP	6.50 ea.
HM4892	Eccentric Plate 1½-3HP (holds trip arm on)	4.50
HM4893	Eccentric Plate 6HP	4.50
K205	Eccentric, Cam Gib Key 1½HP	4.50
K206	Eccentric Cam Gib Key 3-6HP	4.50
HM490	Exhaust Rocker Lever 1½HP	35.75
HM491	Exhaust Rocker Lever 3HP	38.50
HM492	Exhaust Rocker Lever 6HP	43.10
HM493	Exhaust Rocker Push Rod 1½HP	22.75
HM4931	Exhaust Rocker Push Rod 3HP	25.00
HM4932	Exhaust Rocker Push Rod 6HP	27.00
HM494	Flywheel Gib Key (3") 1½HP	5.25

**IHC-MCCORMICK-DEERING MODEL "M" 1½-6HP cont.**

HM4941	Flywheel Gib Key (3 1/2") 1 1/2 HP	5.25
HM4942	Flywheel Gib Key (3½") 3HP	7.00
HM4943	Flywheel Gib Key (4½") 3HP	7.50
HM4944	Flywheel Gib Key (4½") 6HP	7.00
HM4945	Flywheel Gib Key (5") 6HP	7.00
HM495	Fuel Filler Assy. (consists of HM495A, B, C)	33.50
HM495A	Fuel Filler Pipe And Cap	12.00
HM495B	Fuel Filler Pipe Elbow With Fitting	20.50
HM495C	Fuel Filler Nipple To Tank	1.75
HM496	Fuel Pump Check Valve (Early) 1 1/2-6HP	52.50
HM497	Fuel Pump, Eared Cap On Plunger 1½HP	93.25

**(All fuel pumps are cast iron and tested before shipping)**

HM4971	Fuel Pump Plunger Shaft (Eared Cap) 1½HP	30.25
HM498	Fuel Pump, Button Cap On Plunger 1½HP	90.25
HM4981	Fuel Pump Plunger Shaft (Button Top)	20.00
HM499	Fuel Pump 3HP	102.25
HM500	Fuel Pump 6HP	116.50



HM5000	Fuel Pump Lever, For Button Cap 1½HP	22.50
P257	Fuel Pump Checkball, 5/16"	.50
P258	Fuel Pump Checkball, 3/8"	.65
HM5002	Fuel Pump Packing Gland 1½HP (Eared Pump)	9.50
HM5002A	Fuel Pump Packing Gland 1½HP (Button Top Pump)	9.50
HM5003	Fuel Pump, Packing Gland 3HP	9.50
HM5004	Fuel Pump, Packing Gland, 6HP	9.50
HM501	Fuel Pump Packing (Per Foot)	2.00
HM503	Fuel Tank, Galvanized 1½HP	55.50
HM504	Fuel Tank, Galvanized 3HP	62.50
HM505	Fuel Tank, Galvanized 6HP	69.50
HM5050	Fuel Tank Siphon Elbow 1½-6HP	24.50

**(Goes in top of tank-fuel pickup)**

HM5051	Gasket, Carb to Head 1½HP	2.25
HM5052	Gasket, Carb to Head 3HP	2.25
HM50525	Gasket, Carb to Head 6HP	2.75
HM505A	Gasket, Carb Top (Gas) 1½HP	2.75
HM505B	Gasket, Carb Top (Kerosene) 1½HP	2.75
HM505C	Gasket, Carb Top 3HP	2.75
HM505D	Gasket, Carb Top 6HP	4.25
HM50528	Gasket, Crankcase Breather 1 1/2-6HP	1.75
HM5053	Gasket, Cylinder Head (Ignition.) 1½HP	8.50
HM5054	Gasket, Cylinder Head (S/P) 1½HP	9.00
HM5055	Gasket, Cylinder Head 3HP	10.00
HM5056	Gasket, Cylinder Head 6HP	10.50
HM5057	Gasket, Handhole 1½HP	2.00
HM5058	Gasket, Handhole 3HP	2.50
HM5059	Gasket, Handhole 6HP	2.75
HM506	Gasket, Ignitor 1½-6HP	3.25
HM507	Governor Shoe (Fork) 1½HP	42.25
HM5072	Governor Shoe (Fork) 3HP	44.75
HM5074	Governor Shoe (Fork) 6HP	44.75
HM5075	Governor Sleeve (Round Part) 1½HP	60.25

**(Early style, does not use brass collar, will interchange with late style)**

HM5077	Governor Throttle Rod (Long) 1½HP	33.75
HM5078	Governor Throttle Rod (Long) 3HP	39.75

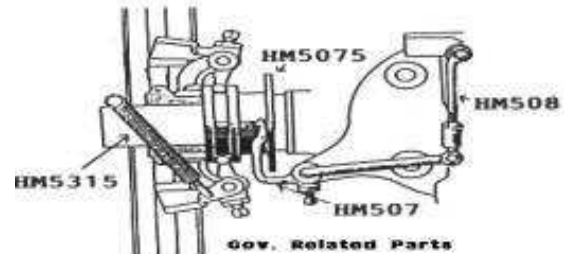

HM5079	Governor Throttle Rod (Long) 6HP	52.50
HM508	Governor Throttle Rod Assy. (Short) 1½HP	33.75
HM509	Governor Throttle Rod Assy. (Short) 3HP	35.75
HM510	Governor Throttle Rod Assy. (Short) 6HP	38.00
HM511	Governor Yoke (holds weights) 1 1/2HP	87.75
HM5112	Handhole Cover, 4 Bolt 1½HP	18.50
HM5114	Handhole Cover, 4 Bolt 3HP	18.50

**IHC-MCCORMICK-DEERING MODEL "M" 1/2-6HP cont.**

HM5116	Handhole Cover, 4 Bolt 6HP	22.50
HM512	Magneto Bracket 3-6HP (WICO "EK")	32.50
HM5143	Magneto, Deadpin ("EK")	4.25
HM5145	Magneto, "EK" Retard Lever Locater Pin & Spring	15.75
HM5146	Magneto IHC "L" Housing End Cap	47.50
HM5147	Magneto, "EK" Trip Rod Only	47.50
HM515	Muffler 1/2HP (Cast iron, like original)	46.75
HM516	Muffler 3HP	65.00
HM5165	Muffler 6HP	99.75
HM518	Nameplate "IHC" 1/2HP	7.00
HM519	Nameplate, "IHC" 3-6HP	7.00
HM520	Nameplate, McCormick-Deering 1/2HP	7.00
HM521	Nameplate, McCormick-Deering 3-6HP	7.00
HM523	Piston Wrist Pin (Ignitor model) 1/2HP	27.00
HM523A	Piston Wrist Pin (S/P model) 1/2HP	27.00
HM5231	Piston Wrist Pin 3HP	31.10
HM5232	Piston Wrist Pin 6HP	34.75
HMR20	Piston Ring 3 1/4" X 1/4" (Ignitor) 1/2HP	6.00 ea.
HMR27	Piston Ring, 3 5/8" X 3/16" (S/P) 1/2HP	6.00 ea.
HMR36	Piston Ring, 4 1/8" X 1/4" 3HP	8.00 ea.
HMR46	Piston Ring, 4 3/4" X 5/16" 6HP	8.00 ea.
HM01	Sparkplug	5.00
HM525	Spring, Compensating Valve 1/2HP	3.25
HM526	Spring, Compensating Valve 3HP	4.00
HM527	Spring, Compensating Valve 6HP	4.00
HM528	Spring, Exhaust Rocker 1/2HP	6.50
HM529	Spring, Exhaust Rocker 3HP	8.00
HM530	Spring, Exhaust Rocker 6HP	8.50
HM531	Spring, Exhaust Push Rod 1/2-3HP	4.75
HM5312	Spring, Fuel Pump Plunger 1/2HP	2.75
HM5313	Spring, Fuel Pump Plunger 3HP	3.00
HM5314	Spring, Fuel Pump Plunger 6HP	3.50
HM5315	Spring, Gov. Spring & Hook 1/2-3HP	20.50
HM5316	Spring, Governor Spring & Hook 6HP	22.25
HM532	Spring, Ignitor Tension 1/2-6HP (Overstrike ignitor)	6.50
HM533	Spring, Ignitor Torsion 1/2-6HP (Overstrike ignitor)	6.50
EK17	Spring, Mag Drive (WICO EK) 1/2-6HP	4.00
EK13	Spring, Mag Return (WICO EK) 1/2-6HP	4.00
HM263	Spring, Needle Valve 1/2-3HP	1.00
HM264	Spring, Needle Valve 6HP	1.25
HM537	Spring, Throttle Butterfly Shaft 1/2-6HP	5.50
HM538	Spring, Exhaust Valve 1/2HP	4.75
HM539	Spring, Exhaust Valve 3HP	4.75
HM540	Spring, Exhaust Valve 6HP	6.00
HM541	Spring, Intake Valve 1/2HP	4.75
HM542	Spring, Intake Valve 3HP	4.75
HM543	Spring, Intake Valve 6HP	6.00
HM545	Throttle Butterfly Assy. (Includes Spring) 1/2HP	33.75
HM5451	Throttle Butterfly Assy. (Includes Spring) 3HP	33.75
HM5452	Throttle Butterfly Assy. (Includes Spring) 6HP	35.75
HM547	Valve, Exhaust 1/2HP	31.50
HM548	Valve, Exhaust 3HP	33.75
HM549	Valve, Exhaust 6HP	40.25
HM5495	Valve, Guide 6HP	52.50
HM550	Valve, Intake W/Threaded End 1/2HP	32.50
HM551	Valve, Intake W/Threaded End 3HP	35.75
HM552	Valve, Intake W/Threaded End 6HP	42.10
HM553	Valve Keeper, Exhaust 1/2HP	7.25
HM554	Valve Keeper, Exhaust 3HP	7.25
HM555	Valve Keeper, Exhaust 6HP	7.25
HM556	Valve Keeper, Intake (2PC.) 1/2HP	12.75
HM557	Valve Keeper, Intake (2PC.) 3HP	12.75
HM558	Valve Keeper, Intake (2PC.) 6HP	12.75



**IHC MCCORMICK-DEERING "LA" & "LB" 1/2-5HP**

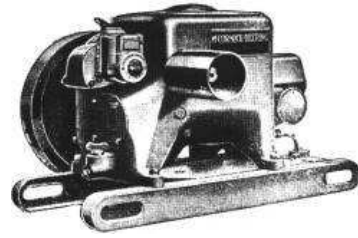

**NO-The LA is not the smaller and the LB the larger. The LA is the earlier model and was made in two sizes. The LB is the later model and was also made in two sizes, 1-1/2 to 2-1/2HP and 3 to 5HP. The easiest way to tell the difference if there is no tag is by looking at the valve rockers. The valve rocker arms on the LA models were oiled by an oil cup on the end of the valve rocker shaft. The LB models were self oiling and there is a tube coming out of the front of the block going into an oil trough filled with felt above the rockers. Just about everything interchanges between both models if they are the same HP. Again there are exceptions but we can help you get it right. It's a good idea for LA owners to order both manuals as the LB manual has very good parts illustrations that again are basically the same parts. The LA's were made from 1934 to mid 1941 and the LB's from 1941-48. Like the 'M's they were all throttle governed.**

L287	Parts Only, Type "L" 1 1/2HP	5.00
L289	Inst. & Parts "LA" With WICO "H" Mag.	3.00
L29	Inst. & Parts "LA" With WICO "AH" Mag	3.00
L30	Instruction & Parts, "LB", 1 1/2-5HP	8.00
LS73	Instruction & Parts, "LB", Radiator Cooled	5.50
HM602	Bearing, Rod 1 1/2-2 1/2HP	20.50
HM701	Carb, Check Valve "LA" & "LB" 1 1/2-5HP	10.00
HM603	Carb, Choke Valve (Round Cover.) 1 1/2-2 1/2HP	5.30
HM604	Carb, Choke Valve (Round Cover.) 3-5HP	6.50
HM6041	Carb, Choke Valve Pin 1 1/2-5HP	6.25

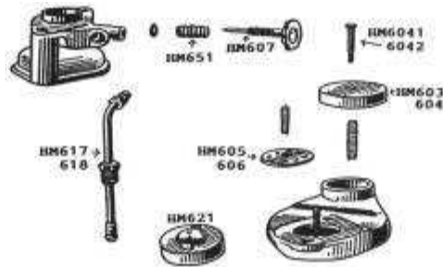

HM605	Carb, Comp. Valve (Flat Disc.) 1 1/2-2 1/2HP	5.00
HM606	Carb, Comp. Valve (Flat Disc.) 3-5HP	5.00
HM6062	Carb, Comp. Valve Pin 1 1/2-5HP	5.00
HM607	Carb, Needle Valve 1 1/2-5HP	16.25
HM610	Crankhandle 1 1/2-5HP	18.50
HM611	Crankhandle Pin 1 1/2-5HP	1.75
HM485	Decal, McCormick-Deering 1 1/2-5HP	3.50 ea.
HM487	Decal, Globe 1 1/2-2 1/2HP	3.50 ea.
HM488	Decal, Globe 3-5HP	5.00 ea.
HM613	Expansion Plug, Bottom 2 3/4", 1 1/2-5HP	3.00
HM6131	Expansion Plug, 1 3/8", 1 1/2-2 1/2HP	2.00
HM6132	Expansion Plug, 1 7/8", 3-5HP	2.00
HM6138	Felt, Crank & Camshaft 1 1/2- 2 1/2HP	3.25
HM6139	Felt, Camshaft 3-5HP	3.25
HM6140	Felt, Crankshaft 3-5HP	3.25
HM614	Felt, Valve Stem "LB" (1 Per Valve) 1 1/2-5HP	1.50
HM614A	Felt, Valve Guide "LB" (2 Per Valve) 1 1/2-5HP	1.50
HM615	Felt, Valve Lever Oil Trough "LB" 1 1/2-5HP	2.75
HM617	Fuel Line Assy. (Complete) 1 1/2-2 1/2HP	20.50
HM618	Fuel Line Assy. (Complete) 3-5HP	21.50
HM619	Fuel Tank (with filler cap) 1 1/2-2HP	57.50
HM620	Fuel Tank (with filler cap) 3-5HP	60.50
HM621	Fuel Filler Cap (For Original Tanks)	12.50
HM622	Gasket, Carb Top 1 1/2-2 1/2HP	1.75
HM623	Gasket, Carb Top 3-5HP	1.75
HM624	Gasket, Carb Bottom 1 1/2-2 1/2HP	1.75
HM625	Gasket, Carb Bottom 3-5HP	1.75

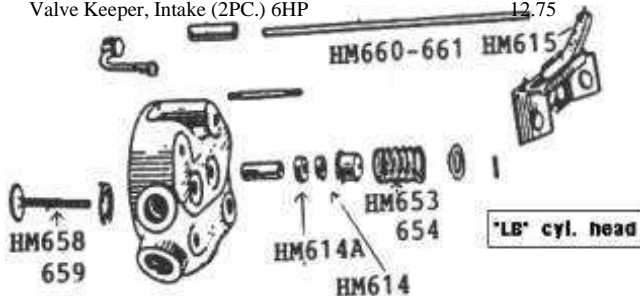

**IHC-MCCORMICK-DEERING MODEL LA/LB cont.**

HM626	Gasket, Cylinder Head 1 1/2-2 1/2HP	7.50
HM627	Gasket, Cylinder Head 3-5HP	8.50
HM628	Gasket, Handhole Cover 1 1/2-5HP	1.75
HM630	Gasket, Mag To Block 1 1/2-2 1/2HP	1.75
HM631	Gasket, Mag To Block 3-5HP	1.75
HM6315	Gasket, Mag To Cap (IHC-1 Mag) 1 1/2-5HP	1.75
HM632	Gasket, Mag Points Cover (WICO "H")	1.75
HM6325	Gasket, Mag Points Cover (WICO "AH")	1.75
HM633	Gasket, Mag Points Cover (IHC-H1 Mag)	1.75
HM634	Gasket, Side Plate 1 1/2-2 1/2HP	7.00
HM635	Gasket, Side Plate 3-5HP	8.00
HM6355	Gasket Set 1 1/2-2 1/2HP	21.00
HM6356	Gasket Set 3-5HP	23.50
HM637	Hopper Lid 1 1/2-5HP	20.00
HM638	Magneto Coil Cover/Cap, IHC H-1	24.00
HM6381	Magneto Coil Cover Screw	.75
HM639	Magneto, IHC H-1 Condenser	9.50
HM640	Magneto, IHC H-1 Coil	65.50
HM6405	Magneto, IHC H-1 Gasket Kit	6.50
HM641	Magneto, IHC H-1 Points	12.50
HM6415	Magneto, IHC H-1 Points Cover	22.50
HM642	Magneto, IHC H-1 Impulse Spring	24.00



Please be sure which mag you have-AH & H-1 parts do not interchange.

HM6423	"AH" WICO Condenser	17.00
HM6424	"AH" WICO Coil (Substitute-needs modified)	75.00
HM6425	"AH" WICO Points	17.50
HM643	"AH" Coil Cover with Leadout	50.50
HM6435	"AH" Impulse Spring	27.50
HM644	Muffler 1 1/2-2 1/2HP	20.00
HM645	Muffler 3-5HP	22.50
HM646	Nameplate "LA" 1 1/2-2 1/2HP	7.00
HM647	Nameplate "LA" 3-5HP	7.00
HM648	Nameplate "LB" 1 1/2-2 1/2HP	7.00
HM649	Nameplate "LB" 3-5HP	7.00
HM649A	Oil Cup "LA", Valve Rocker Shaft	10.95
HM650	Oil Seal, 1 1/2-2 1/2HP	12.00
HM650A	Oil Seal, Camshaft 3-5HP	14.50
HM650B	Oil Seal, Crankshaft 3-5HP	14.50
HMR14	Piston Ring, 3 1/8" X 1/8" 1 1/2-2 1/2HP	6.00 ea.
HMR16	Piston Ring, 3 1/8" X 1/4" Oil, 1 1/2-2 1/2HP	7.00 ea.
HMR32	Piston Ring, 4" X 1/8" 3-5HP	8.00 ea.
HMR33	Piston Ring, 4" X 1/4" Oil, 3-5HP	10.50 ea.
HM650D	Pulley 4" X 4" with keyway 1 1/2-5HP	83.10

**Pulleys are cast iron engine pulley but not repro of original.**

HM650G	Pulley, Gib Key 1 1/2-5HP	5.00
HM01	Sparkplug	5.00
HM651	Spring, Carb Needle Valve 1 1/2-5HP	1.00
HM652	Spring, Crankhandle 1 1/2-5HP	5.25
HM6525	Spring, Throttle Assy. 1 1/2-5HP	3.00
HM654	Spring, Valve "LB" 1 1/2-5HP (Will Work On "LA")	4.75
HM656	Throttle Valve Assy. 1 1/2-2 1/2HP	31.50
HM6561	Throttle Valve Assy. 3-5HP	31.50
HM657	Valve Cover "LA" 1 1/2-2 1/2HP	46.00
HM6572	Valve Cover "LA" 3-5HP	47.50
HM6574	Valve Cover "LB" 1 1/2-2 1/2HP	46.00
HM6576	Valve Cover "LB" 3-5HP	47.50

\*\*\*\* Valve covers are excellent fiberglass repros -Satisfaction Guaranteed

HM6578	Valve Cover Wing Nut 1 1/2-5HP	4.00
HM657A	Valve Cover Stud 1 1/2-5HP	2.50
HM658	Valve, Exhaust Or Intake 1 1/2-2 1/2HP	24.00
HM659	Valve, Exhaust Or Intake 3-5HP	24.00
HM6595	Valve Oiler Tube With Regulator 1 1/2-5HP "LB" only	30.25
HM660	Valve Push Rod 1 1/2-2 1/2HP	8.25
HM661	Valve Push Rod 3-5HP	9.50
HM664	Valve Rocker Arm Adj. Screw 1 1/2-5HP	6.50
HM665	Valve Rocker Arm Exhaust "LA" 1 1/2-2 1/2HP	35.75
HM666	Valve Rocker Arm Exhaust "LA" 3-5HP	35.75
HM667	Valve Rocker Arm Ex & Int. "LB" 1 1/2-2 1/2HP	35.75
HM668	Valve Rocker Arm Exhaust "LB" 3-5HP	35.75
HM669	Valve Rocker Arm Intake "LA" 1 1/2-2 1/2HP	35.75
HM670	Valve Rocker Arm Intake "LA" 3-5HP	35.75
HM671	Valve Rocker Arm Intake "LB" 3-5HP	35.50
HM6715	Valve Seat "LA" & "LB" 1 1/2-2 1/2HP	8.00

HM6716	Valve Seat "LA" & "LB" 3-5HP	8.00
HM673	Valve Spring Retainer "LB" 1 1/2-5HP	3.00

**\*\*Note: We now have new "LA" rocker arm brackets available.**

**JOHN DEERE "E" 1 1/2-6HP**

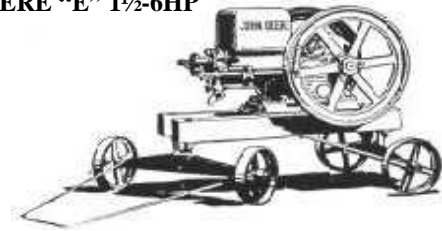

You may have an early JD that has the Waterloo name on the nameplate, or possibly you have a not so common sparkplug model, but regardless, all "E's" are basically the same which makes identifying parts and ordering a snap. If you don't see the parts you need on this list give us a call as we usually have a fair selection of used parts. NOTE: Besides offering magneto and ignitor repair we also can repair your broken governor by replacing the gear, and/or threaded end, or brazing broken yokes (holds the weights). If you have extra broken or good gov. parts, we would be interested in buying or trading for them.

L39	Instruction & Parts, 1 1/2-6HP	3.50
L391	Serial Number List	.50
HM700	Bearing, Rod 1 1/2HP	28.25
HM7001	Bearing, Rod 3HP	33.75
HM70015	Bearing, Rod 6HP	40.25
HM7002	Bearing, Main 1 1/2HP	33.75
HM7003	Bearing, Main 3HP	37.50
HM70035	Bearing, Main 6HP	49.75
HM7004	Bushing, Connecting Rod 1 1/2HP	14.25
HM70041	Bushing, Connecting Rod 3HP	18.50
HM70043	Bushing, Connecting Rod 6HP	21.50
HM7005	Bushing, Gov. Or Cam Shaft 1 1/2-3HP	20.50
HM7006	Bushing, Camshaft 6HP	30.25
HM7007	Bushing, Governor shaft 6HP	30.25
HM701	Carb Check Valve 1 1/2-6HP	10.00
HM702	Carb Choke Plate 1 1/2-3HP	5.00



HM703	Carb Needle Valve 1 1/2-3HP	16.75
HM7031	Carb Needle Valve 6HP	20.00
HM704	Carb Needle Valve Seat 1 1/2-3HP	25.00
HM7041	Carb Needle Valve Seat 6HP	28.75
HM7042	Connecting Rod Cap Bolt 1 1/2-3HP	3.00
HM7043	Crankcase Cover Oil Guard 1 1/2 HP	16.75
HM7045	Crankhandle 1 1/2 -6 HP	13.25
HM7046	Crankhandle Pin 1 1/2HP (6HP available)	6.25
HM705	Decal, John Deere 1 1/2HP	2.50 ea.
HM706	Decal, John Deere 3HP	3.00 ea.
HM707	Decal, John Deere 6HP	4.50 ea.
HM708	Exhaust Lever 1 1/2HP	42.25
HM709	Exhaust Lever 3HP	42.50
HM7092	Exhaust Lever 6HP	66.25
HM7095	Exhaust Lever Pivot Bolt 1 1/2-3HP	14.10
HM7096	Exhaust Lever Pivot Bolt 6HP	18.50
HM710	Exhaust Lever Adjusting Bolt	14.10
HM7105	Exhaust Push Rod 1 1/2HP	25.00
HM7106	Exhaust Push Rod 3HP	31.10
WEB07	Exhaust Lever Pivot Oil Cup 1 1/2-3HP	2.50
HM7108	Flywheel Key 1 1/2-3HP	10.50
HM711	Fuel Line Assy. Complete 1 1/2HP	30.25
HM712	Fuel Line Assy. Complete 3HP	31.50
HM713	Fuel Line Assy. Complete 6HP	32.50
HM714	Fuel Tank, Square Corners-galvanized 1 1/2HP	44.50
HM714F	Fuel Tank, Fiberglass 1 1/2HP (Looks Original)	50.50
HM715	Fuel Tank, Square Corners 3HP	51.00
HM715F	Fuel Tank, Fiberglass 3HP	54.50
HM7153	Fuel Tank, Square Corners 6HP	67.50



**JOHN DEERE "E" 1 1/2-6HP cont.**

HM7155	Fuel & Oiler Filler Plug	10.50
HM716	Gasket, Cylinder Head 1/2HP	8.50
HM717	Gasket, Cylinder Head 3HP	9.00
HM7175	Gasket, Cylinder Head 6HP	13.50



HM718	Gasket, Crankcase Bottom (Takes 2) 1 1/2HP	5.50
HM719	Gasket, Crankcase Bottom 3HP	6.50
HM7195	Gasket, Crankcase Bottom 6HP	11.00
HM720	Gasket, Crankcase Top 1 1/2HP	5.50
HM721	Gasket, Crankcase Top 3HP	6.50
HM7215	Gasket, Crankcase Top 6HP	11.00
HM722	Gasket, Ignitor 1 1/2-6HP	3.75
HM723	Gasket, Governor Cover 1 1/2HP	4.50
HM724	Gasket, Governor Cover 3HP	5.25
HM7245	Gasket, Governor Cover 6HP	7.50
HM725	Gasket, Magneto Cover 1 1/2-6HP	1.75
HM726	Gasket, Magneto, Oil Seal 1 1/2-6HP	3.75
HM7261	Gasket Set 1 1/2HP	38.00
HM7262	Gasket Set 3HP	42.25
HM7263	Gasket Set 6HP	62.50
HM7264	Gear, Cam 1 1/2 HP	102.25
HM7264B	Gear, Cam 3HP	116.50
HM7265	Governor Gear Replacement 1 1/2-3HP **	60.00
HM7265A	Governor Gear Replacement 6HP **	67.50
HM7266	Gov. Threaded End Replacement 1 1/2-3HP **	39.25

**\*\*Send us your governor spindle shaft for these repairs.**

HM7269	Gov. Speed Adjusting Knob & Screw	16.75
HM72691	Ignitor Trip Assy. (complete w/spring) 1 1/2-3HP	79.50
HM72693	Ignitor Trip Finger Bracket 1 1/2-3HP	33.75
HM72695	Ignitor Trip Finger 1 1/2-6HP	33.75
HM72696	Ignitor Trip Finger Pin 1 1/2HP	6.25
HM7269A	Ignitor Anvil 1 1/2-6HP	42.25
HM72697	Ignitor Anvil Pin	7.00
W113A	Ignitor Mica Tube (1 3/4" Length)	3.30
W114I	Ignitor Mica Washers (3/4" Stacks)	2.75
W115	Ignitor Points 1 1/2-6HP	4.00
W1153A	Ignitor Points, "Special" 1/8" dia. stem, 5/16" length.	14.10
W1153B	Ignitor Points, "Special" 3/16" dia. stem, 5/16" length.	14.10
W117	Ignitor Wire (Per Foot)	1.00
HM7269B	Magneto Armature Comm. End (Rear Shaft)	42.50
HM7269C	Magneto Armature Drive End (Front Shaft)	47.50
HM7269D	Magneto Name Band	14.00
HM7269E	Magneto Carbon Brush (Tower Brush)	5.00
HM7269G	Magneto Housing	245.00
HM7269H	Magneto Housing End Cap (Rear Cover)	47.50
HM7269J	Magneto Leadout Tower	25.00
HM7269K	Magneto Hole Cover Plate 1 1/2 - 6 HP	12.50
HM727	Muffler 1 1/2-3HP	42.50
HM7275	Muffler 6HP	42.00
HM728	Oil Pan 1 1/2HP	26.00
HM729	Oil Pan 3HP	28.00
HM7291	Oil Pan 6HP	37.50
HM7295	Piston 1 1/2HP (Wrist Pin Not Included)	162.50

**(Oversized pistons available to fit bored cylinders.)**

HMR23	Piston Ring, 3 1/2" X 1/4" 1 1/2HP	6.00 ea.
HMR43	Piston Ring, 4 1/2" X 5/16" 3HP	8.00 ea.
HMR526	Piston Ring, 6" X 5/16" 6HP	17.50 ea.
HM730	Piston Wrist Pin 1 1/2HP	27.00
HM731	Piston Wrist Pin 3HP	27.00
HM7312	Piston Wrist Pin 6HP	30.50
HM7315	Pulley 1 1/2HP (bolt on)	47.50
HM732	Spring, Exhaust Lever 1 1/2-3HP	7.25
HM7325	Spring, Governor Control 1 1/2-6HP	3.00
HM7327	Spring, Governor spindle rod	3.50
HM733	Spring, Ignitor Tension 1 1/2-6HP	5.50
HM734	Spring, Ignitor Torsion (Small) 1 1/2-3HP	5.50
HM735	Spring, Ignitor Trip Finger 1 1/2-6HP	5.50
HM736	Spring, Needle Valve 1 1/2-3HP	1.00
HM738	Spring, Exhaust Valve 1 1/2-3HP (6HP available)	4.75



**JOHN DEERE "E" 1 1/2-6HP cont.**

HM739	Spring, Intake Valve 1 1/2-3HP (6HP available)	4.75
HM740	Valve, Exhaust or Intake 1 1/2HP	31.50
HM741	Valve, Exhaust or Intake 3HP	33.25
HM742	Valve, Exhaust or Intake 6HP	39.10

**Monitor 1 1/4HP model "VJ"**

LS104	Operating Instructions 1 1/4-8HP	3.50
LS103	Part's Only	2.00
L46	Monitor Catalog #45 (Products)	12.00
L465	Monitor Catalog #51E (Products)	9.50
M55	Bearing, Rod	30.50
M55C	Carb (Mixer) Needle Valve	18.50
HMR22	Piston Ring 3 1/2" X 3/16"	6.00
M55E	Valve, Exhaust	31.50
M55I	Valve, Intake	31.50

**Valve Springs-Suggest using Hercules 1 1/2 HP as follows:**

HM406	Spring, Ex. Valve 1 1/2-2HP	4.75
HM408	Spring, Intake Valve 1 1/2-2HP	4.75

**Nelson Brothers "U or T" 1 3/4-3HP**

We're calling this a model "U" or "T" but not positive we have it correct. We believe the "T" had spoke flywheels and the "U" solid flywheels. The part's book shows numerous part numbers starting with T. The main part to look at is the magneto bracket which mounts at an angle on top of the cyl. head. The mixer mounts on the side and may be gas only (hit & miss) or kerosene (throttle governed). Unfortunately the part's book doesn't give specific part #'s for the different HP's. The part's listed here are for the 1 3/4HP but some of the magneto trip parts may interchange.

\*\*\*Also sold as Sattley, Jumbo, Monarch, Sun, etc. Read description carefully-please call if you have any questions. We have some used original parts for these engines.

L482	Inst & Parts, Nelson Bros "T or U", WICO Mag	6.00
HM757	Bearing, Connecting Rod 1 3/4 HP	30.25
HM7572	Bearing, Main 1 3/4 HP (One side only)	33.75
HM7574	Carb (Mixer) Needle Valve 1 3/4HP	18.50
HM7576	Ex. Rocker Arm 1 3/4 HP	38.00
HM758	Gasket, Carb (Mixer) 1 3/4 HP	3.00
HM758B	Gasket, Magneto Bracket	3.00
HM758H	Gasket, Cylinder Head	10.00
HM758N	Magneto Bracket (mounts on head)	95.00
HM759	Magneto "EK" Trip Bracket #16	42.25
HM7593	Magneto "EK" Trip Rod & Bushing	27.00
HM7595	Magneto "EK" Trip Rocker #14 (HM7595 includes EK272)	42.50
EK272	Magneto "EK" Trip Rocker Retard Lever	5.00
HM7597	Magneto "EK" Trip Rod Drive Spring	4.00
HM7598	Magneto "EK" Trip Rod Return Spring	4.00
HMR30	Piston Ring 3 3/4" X 3/16" (takes 3)	6.00
HM760	Valve, Exhaust 1 3/4 HP	31.50
HM7605	Valve, Intake 1 3/4 HP	31.50

**SATTLE & NEW SATTLE 1 1/2-1 3/4HP**

**Solid flywheels, Wico EK mag, gov. weights attach to cam gear, these are look-a-likes with a few differences. If you're not sure call us.**

L57	New Sattley Instructions & Parts	4.00
NS100	Carb (Mixer) Choke Plate	5.00
NS105	Carb (Mixer) Fuel Needle Valve	18.50
NS107	Carb (Mixer) Fuel Needle Valve Seat	20.50
NS109	Crankguard	28.00
NS110	Decal-New Sattley	5.00
NS111	Fuel Line Assy. with 3/16" tubing	8.25
NS114	Fuel Tank	55.50
NS121C	Gasket, Carb to Head	2.00
NS20	Gasket, Cylinder Head	9.00
NS45	Magneto Bracket (Late Style)	27.00
NS50	Magneto "EK", Trip Rocker	42.25
NS51S	Magneto Trip Drive Spring	4.00
NS52S	Magneto Trip Return Spring	4.00
HMR30	Piston Ring 3 3/4" X 3/16" (takes 3)	6.00 ea.
NS55	Valve, Exhaust or Intake	31.50
NS56	Valve, Ex. Rocker -New Sattley NS121 (5 1/2" lgth)	38.00
NS56S	Valve, Ex. Rocker-Sattley (Early New Sattley) (6 1/4")	42.25

## NOVO MODEL "S" 1½-10HP

Due to the fact the Novo Company did the numbers game with their HP ratings while they were in production, we'll have to ask you some questions if you have a 1, 2½, 3½, or 5HP. Our parts book shows the 1½, 2, 3, 4, 6, 8, & 10HP. Add ½HP and we believe the first group is the same as



the 1½ to 6HP with the exception of the 2HP. Sound like we're confused? We have a lot of collective experience here at Hit & Miss, but we've been left shaking our heads more than once when we thought we had a good grip on something only to be proven wrong. The Novo we're referring to in this parts list is the standard "S" with battery and coil ignition, either hit & miss or throttle governed. The two mags used on Novo engines were Bosch and the WICO "EK". We do list "EK" mag parts in our catalog and may have brackets and trip assemblies for this

engine. Now if you have a Novo that needs a WICO "EK" don't just go and buy any "EK" and expect it to fit. The reason for this is the trip roller on the bottom of the mag is turned 90° and it requires some experience to modify a standard mag to fit correctly. We can provide this service and also rebuild your mag if necessary. We do have some used parts available as well as a few NOS parts.

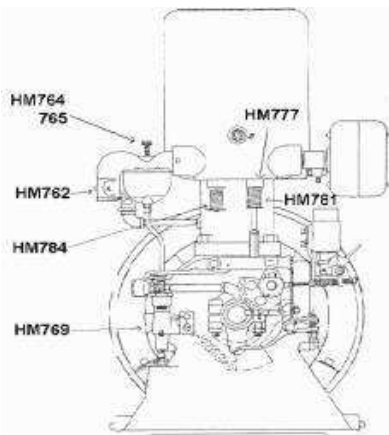

L49	Instructions, 1½-10HP, Model "S"	5.00
L491	Parts, 1½-10HP, Model "S", Kerosene. & Gas	6.00
<b>(This is an excellent part's breakdown-good pictures)</b>		
HM762	Carb, Air Throttle (Choke) 3-4HP	21.50
HM763	Carb, Filler Plug (Brass) 1½-10HP	12.75
HM764	Carb, Needle Valve 1½-2HP	18.50
HM765	Carb, Needle Valve 3-5HP	18.50
HM7655	Carb Siphon Tube S-29, 3-6HP	15.75
HM766	Circuit Breaker Spring 1½-6HP	18.50
HM767	Circuit Breaker Spring Stop 1½-10HP	2.50
HM7672	Circuit Breaker Block 1½-10HP	27.00

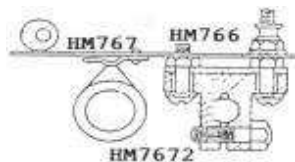

HM768	Decal, 1½-10HP	6.00 ea.
HM769	Fuel Pump 2-10HP	100.25
P255	Fuel Pump Check Ball ¼"	.50
P258	Fuel Pump Check Ball 3/8"	.65
HM770	Fuel Pump Lever 2-6HP	31.50
HM771	Fuel Pump Nut (Brass) 1½-10HP	22.75
HM7712	Fuel Pump Nut Gland 1½-10HP	7.00
HM7715	Fuel Pump Plunger 1½HP	20.50
HM772	Fuel Pump Plunger 2-10HP	20.50
HM7725	Fuel Pump Plunger Spring 2-10HP	3.00
HM7726	Gear, Crankshaft Pinion 2-3HP	80.50
HM7727	Governor Latch 1½-3HP	25.00
HM7728	Governor Latch 4-8HP	25.00

HM7729	Governor Latch Flat Spring 1½-10HP	10.75
HM772A	Governor Weight 1½-2HP	54.75
HM772B	Governor Weight 3-4HP	54.75
HM772C	Governor Weight 6-10HP	58.00
HM773	Governor Weight Pin 1½-10HP	18.50
HM7732	Governor Weight Adjusting Screw 1½-10HP	8.25
HM7734	Governor Weight Spring Adj. Stud 1½-10HP	8.25
HM774	Hopper Lid (Cast Iron) 1½-10HP	23.75
HM775	Nameplate, Oval 1½-10HP	17.50
HMR31	Piston Ring, 3¾" X ¼" 1½-2HP	6.00 ea.
HMR43	Piston Ring, 4½" X 5/16" 3HP	8.00 ea.
HMR48	Piston Ring, 5" X 3/8" 4HP	12.00 ea.
HMR52	Piston Ring, 5¾" X 3/8" 6HP	14.00 ea.
HM02	Sparkplug	5.00
HM7725	Spring, Fuel Pump Plunger 2-10HP	3.00
HM781	Spring, Exhaust Valve 2-6HP	5.00
HM7812	Spring, Governor 1½-10HP	5.00
HM784	Spring, Intake Valve 2-6HP	5.00
HM7755	Valve Cage 1 1/2HP	91.25
HM7756	Valve Cage Copper Gasket 1 1/2HP, 1 1/4ID, 1 1/2OD	4.00
HM7758	Valve Cage 2HP	91.25
HM776	Valve Cage 3HP	91.25
HM7761	Valve Cage 4HP	94.25
HM7765	Valve Cage Copper Gasket 3-4HP	4.00
HM7768	Valve Cage Nut 2HP	42.25
HM777	Valve Cage Nut 3-4HP	42.25
HM7773	Valve, Exhaust 1 1/2HP	34.75
HM7775	Valve, Exhaust 2HP	34.75
HM778	Valve, Exhaust 3HP	37.50
HM779	Valve, Exhaust 4HP	38.50
HM7795	Valve, Exhaust 6HP	46.75
HM780	Valve, Exhaust Adjusting Nut 2-4HP	16.75
HM7814	Valve, Intake 1 1/2HP	31.50
HM7815	Valve, Intake 2HP	31.50
HM782	Valve, Intake 3HP	34.75
HM783	Valve, Intake 4HP	37.50
HM7835	Valve, Intake 6HP	42.25
HM785	Valve, Stem Collar (Spring Retainer)	2.50

## OTTAWA

**Note: We're not strong on Ottawa but can point out that L52 is for 2HP model BS and 4-5HP model TE (kerosene models-throttle governed) and 4HP mode ES (gasoline hit & miss governed) from approx 1921 to 1928. L53 is for an earlier hit & miss model LS (HP unknown) with either a "J" mixer or the more common brass mixer. There are several different HP's and models of Ottawa that are not covered here but we'll do the best we can to help you or send you in the right direction. Some used parts are available.**

L52	Instruction & Parts, 2HP-BS & 4&5HP-TE	2.50
<b>Engine and Log, Limb &amp; Tree Saw Parts</b>		
L53	Instruction & Parts, Log & Tree Saw, "LS-E"	2.00
L535	Catalog, 5HP With WICO "EK" & Log Saw	8.50
M59	Carb Needle (For Brass Carb)	18.50
M60L	Carb Needle (Long, start side) 4-5HP "TE" 1/4" stem	18.50
M60	Carb Needle (Long, start side) 4-5HP "TE" 5/16" stem	18.50
M61S	Carb Needle (Short, fuel side) 4-5HP "TE" 1/4" stem	18.50
M61	Carb Needle (Short, fuel side) 4-5HP "TE" 5/16" stem	18.50
M63	Carb Needle Valve Seat, Fuel Side	19.25
M634	Carb Needle Valve Seat, Start Side	19.25
<b>(Please give diameter of your needle or seat-1/4" or 5/16")</b>		
M64	Exhaust Valve Rocker Arm 4-5HP TE	40.25
M642	Intake Valve Rocker Arm 4-5HP TE	37.50
M635	Fuel Tank w/brackets (log saw, attaches to head)	62.50
M65	Pushrod, Ex. or Intake, 4-5HP TE (kerosene)	16.10
M66	Pushrod Adj. End 4-5HP TE	17.25
M70	Valve, Ex. or Intake 4-5HP TE	33.75

**We can make valves for all models.**

## STOVER 1½HP 'KE', 1 1/2, 2 & 3HP 'KA'

These engines were open crankcase, hit & miss or throttle governed, WICO "EK" magneto (except the 1 1/2 "KA" may have a new style Webster mag), and had solid flywheels with five round holes. Some of these parts may interchange with some other 'K' models. The 1 1/2 KE has the fuel tank bolted on to the carb with four screws.

**STOVER 1½HP "K & KE", 2 & 3HP "KA" cont.**

L62	Instruction & Parts, 2HP "K" ("KA")	4.00
LS130	Instruction & Parts, 3HP "K" ("KB")	3.50
LS134	Instruction & Parts, 3HP "K" ("KF")	3.00

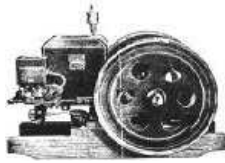

HM800	Bearing, Rod 2HP	31.50
HM8001	Bearing, Rod 3HP	33.75
HM80014	Bearing, Main 2HP	33.75
HM80015	Bearing, Main 3HP	35.75
HM8006	Bushing, Connecting Rod 2HP	14.10
HM8007	Bushing, Connecting Rod 3HP	15.00
HM836A	Carb Needle Valve, KE 1½HP	19.25
HM801	Carb Needle Valve 2-3HP	18.50
HM802	Carb Needle Valve Seat 2-3HP	18.50
HM855	Carb Fuel Line Check Valve 1½HP	14.00
HM213	Carb Fuel Line Check Valve 2-3HP	4.50
HM837	Crankguard 2HP	54.75
HM836	Crankhandle 1½HP	44.50
HM8045	Crankhandle 2HP	44.50
HM8046	Crankhandle 3HP	44.50
HM805	Decal	3.50 ea.
HM838	Exhaust Rocker Lever 1½HP "K" K155	44.75
HM8384	Exhaust Rocker Lever 1½HP "KE" E145	44.75
HM8386	Exhaust Rocker Bracket 1½HP "KE" 8K1	46.75
HM839	Exhaust Rocker Lever 2HP	35.75
HM840	Exhaust Lever Bracket, 2HP	46.75
HM8095	Exhaust Rocker Lever Pin Stover 2-3HP KA	8.25
HM814	Fuel Line Assembly Complete 2-3HP	18.50
HM842	Fuel Tank 1½HP (bolts on carb)	57.50
HM8151	Fuel Tank (Hanger Inc./Not Installed) 2-3HP	54.50
HM816	Gasket, Carb To Head 2-3HP	2.00
HM818	Gasket, Cylinder Head 2HP	8.50
HM819	Gasket, Cylinder Head 3HP	10.00
HM8425	Governor Speed Change Assy. 2-3HP	83.10
HM845	Magneto Bracket (Wico EK) 2-3HP	48.25
EK11	Rocker Arm Group 2-3HP (Wico EK)	27.50
EK14	Armature Return Spring 2-3HP (Wico EK)	4.00
EK24	Trip Finger Assy. 2-3HP (Wico EK)	65.10
EK21	Spring, Trip Finger Support #2 2-3HP (Wico EK)	2.00
EK22	Support For #2 Armature Spring 2-3HP (Wico EK)	9.00
EK23	Support & Rocker Stud With Nut 2-3HP (Wico EK)	12.50
HM846	Muffler 1½HP	27.50
HM822	Muffler 2-3HP	28.50
HMR15	Piston Ring, 3 1/8" X 1/4" 1½HP	6.00 ea.
HMR23	Piston Ring, 3½" X 1/4" 2HP	6.00 ea.
HMR37	Piston Ring, 4¼" X 1/4" 3HP	8.00 ea.
HM8245	Piston Wrist Pin 2HP	15.00
HM8246	Piston Wrist Pin 3HP	17.25
HM01	Sparkplug	5.00
HM531	Spring, Exhaust Lever Push Rod 2-3HP	4.75
HM263	Spring, Needle Valve	1.00
HM829	Spring, Exhaust Valve 2-3HP	4.75
HM830	Spring, Intake Valve 2-3HP	4.75
HM849	Valve, Exhaust Or Intake 1½HP "K-KE"	31.50
HM833	Valve, Exhaust Or Intake 2HP	31.50
HM834	Valve, Exhaust Or Intake 3HP	32.50

**STOVER "CT" 1, 2, 3, & 4**

The 'CT' models look similar to the 'KA' except they have an enclosed crankcase. The serial number tag may make it easy by having the model on it, or it may just have a TA in front of the serial number as the Stover "Economy" (Sold by Sears-three teardrop holes in flywheel). You don't need a tag to correctly identify these engines.

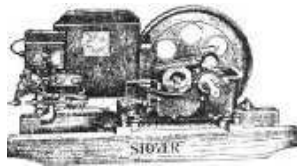

**STOVER "CT" 1, 2, 3, & 4 cont.**

Just give us the part # off the head, block, or backside of the flywheels. It will be helpful to tell us if your engine is hit and miss or throttle governed. All CT's used the Wico 'EK' magneto and we have all the related parts for the trip assembly including the trip finger bracket (on exhaust push rod). Good part's books and a good supply of new and used parts make it likely that we can help with your restoration.

L58	Instruction & Parts, CT1-CT2-CT3-CT4	4.50
HM800	Bearing, Rod CT 1-2	31.50
HM8001	Bearing, Rod CT-3	33.75
HM80012	Bearing, Rod CT-4	35.75
HM80013	Bearing, Main CT-1	33.75
HM80014	Bearing, Main CT-2	33.75
HM80015	Bearing, Main CT-3	35.75
HM80016	Bearing, Main CT-4	40.25
HM8006	Bushing, Conn. Rod CT 1-2	14.10
HM8007	Bushing, Conn. Rod CT-3	15.00
HM8008	Bushing, Conn. Rod CT-4	18.50
HM801	Carb, Needle Valve CT 1-4	18.50
HM802	Carb, Needle Valve Seat CT 1-4	18.50
HM213	Carb, Check Valve CT 1-4	4.50
HM804	Carb, Choke Plate CT 1-3	7.00
HM8044	Crankhandle, CT-1	44.50
HM8045	Crankhandle, CT-2	44.50
HM8046	Crankhandle, CT-3	44.50
HM805	Decal, CT 1-4	3.50 ea.
HM807	Exhaust Rocker Lever CT-1	40.25
HM808	Exhaust Rocker Lever CT-2	35.75
HM809	Exhaust Rocker Lever CT-3	48.25
HM8091	Exhaust Rocker Lever CT-4	54.75
HM8095	Exhaust Lever Pin "CT 1-3"	8.25
HM8098	Exhaust Lever Pin "CT-4"	14.10
HM810	Exhaust Lever Bracket CT-1	46.75
HM8101	Exhaust Lever Bracket CT-2	46.75
HM8103	Exhaust Lever Bracket CT-3	52.50



HM811	Fuel Filler Spout With Lid CT 1-4	48.25
HM812	Fuel Filler Spout Lid (Only) CT 1-4	14.10
HM813	Fuel Line Assy. CT 1-4	10.25
HM815	Fuel Tank, (Hanger inc./not Installed) CT 1-3	56.50
HM815A	Fuel Tank (Hanger inc./not installed) CT 4	67.50
HM816	Gasket, Carb to Head CT 1-3	2.00
HM817	Gasket, Cylinder Head CT-1	8.50
HM818	Gasket, Cylinder Head CT-2	8.50
HM819	Gasket, Cylinder Head CT-3	10.00
HM8191	Gasket, Cylinder Head CT-4	10.50
HM8191A	Gasket, Enclosure Plate CT1-4	2.00
HM8191G	Gasket, Round Gov. Cover CT1-3	2.00
HM8192	Gasket & Felt Set, Crankcase Cover CT-1	13.00
HM8193	Gasket & Felt Set, Crankcase Cover CT-2	13.50
HM8194	Gasket & Felt Set, Crankcase Cover CT-3	14.50
HM8195	Gasket & Felt Set, Crankcase Cover CT-4	16.50
HM820	Gib Flywheel Key CT 1-3	11.75
HM8203	Governor Cover (Round shield)	17.50
HM8204	Governor Détente Lever (top lever to governor. rod)	46.75
HM8206	Governor Weight CT 1-3	13.25
HM8207	Governor Weight Pin CT 1-3	2.25

**WICO 'EK' Magneto Trip Parts**

EK11	Rocker Arm Group	27.50
EK14	Armature Return Spring	4.00
EK24	Trip Finger Assy.	65.10
EK21	Spring, Trip Finger Support #2	2.00
EK22	Support for #2 Armature Spring	10.00
EK23	Support and Rocker Stud w/nut	14.00
HM821	Magneto Bracket WICO "EK" CT 1-4	40.25
HM822	Muffler, CT 1-3	28.50
HM823	Muffler, CT-4	32.00
HM824	Nameplate, CT 1-4	9.50
HMR18	Piston Ring, 3 1/4" X 3/16", CT-1, 2 required	6.00 ea

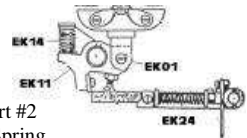

**STOVER "CT" 1, 2, 3, & 4 cont.**

HMR19	Piston Ring, 3-1/4" X 3/16", CT1, oil, 1 required	7.00 ea
HMR23	Piston Ring, 3-1/2" X 1/4", CT2, 2 required	6.00 ea
HMR24	Piston Ring, 3-1/2" X 1/4", CT2, oil, 1 required	7.00 ea
HMR37	Piston Ring, 4 1/4" X 1/4", CT3, 2 required	8.00 ea
HMR38	Piston Ring, 4 1/4" X 1/4", CT3, oil, 1 required	10.50 ea
HM8244	Piston Wrist Pin, CT-1	15.00
HM8245	Piston Wrist Pin, CT-2	15.00
HM8246	Piston Wrist Pin, CT-3	17.25
HM8247	Piston Wrist Pin, CT-4	19.25
HM01	Sparkplug	5.00
HM531	Spring, Exhaust Push Rod CT 1-3	4.75
HM826	Spring, Exhaust Rocker Lever CT 1-3	7.50
HM8202	Spring, Governor Compensating CT 1-4	10.50
HM263	Spring, Needle Valve	1.00
HM829	Spring, Valve Exhaust CT 1-3	4.75
HM830	Spring, Valve Intake CT 1-3	4.75
HM831	Spring Retainer Washer CT1-4	2.25
HM832	Valve, Exhaust Or Intake CT-1	31.50
HM833	Valve, Exhaust Or Intake CT-2	31.50
HM834	Valve, Exhaust Or Intake CT-3	32.50
HM835	Valve, Exhaust or Intake CT-4	34.500

**WITTE "HEADTYPE" 1 1/2-7HP**

The first engines of this style appeared in 1922 and for approximately the first year they were equipped with a Bosch oscillating magneto mounted on the side of the block. They were designated as models 'B' and 'C' for the first five years of production, and later models (approx. 1927 on) as 'F', 'H', 'K' and 'J'. Again, the number's game was played and HP's were raised by one. When ordering parts please give us the diameter of your piston so we can help you order the correct parts. For instance, there is a 3HP with a 3-3/4" bore and a 3HP with a 4-1/4" bore and Witte chose not to put the model on the serial tag. Some serial tags have 1/2 added to the HP (again, the diameter of the cyl. is the most important information you can give us). At one time we had a 2HP, 2-1/2HP, and 3HP in the engine barn, all the same size. We can tell you that the enclosed crankcase engines were self-oiling, and had Timken bearings. The 'B' & 'C' had one-piece blocks and the 'F' & 'H' had detachable water hoppers. Now it gets easier. Many of the parts required to make the

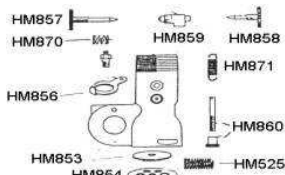
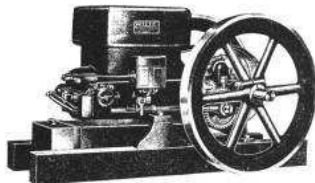

engines run will interchange. We have some used parts and we'll try to help you with technical advice.

L65	Instruction & Parts 2-25HP	4.00
LS147	Parts Only, "F" & "H", 2-30HP	2.00
L660	Serial Number List	.50
LS1455	Advertising, Approx. 1928, 6 pages	2.00
HM851	Cam Gear Oiler Nipple 2-5HP	13.25
HM853	Carb Air Valve Disc. 2-4HP	1.50
HM8535	Carb Air Valve Disc 5-6HP	1.50
HM854	Carb Air Valve Plate 2-4HP	14.10
HM8545	Carb Air Valve Plate 5-6HP	16.10
HM855	Carb Check Valve 1/8" P/T (All)	14.00
HM856	Carb Fill Hole Lid 2-4HP	7.75
HM8565	Carb Fill Hole Lid 5-6HP	10.75
HM857	Carb Needle Valve (Start) 2-5HP	19.25
HM858	Carb Needle Valve (Fuel) 2-5HP	18.50
HM859	Carb Needle Valve Seat 2-5HP	33.75
HM860	Carb Speed Adj. Knob & Screw 2-5HP	14.25
HM861	Crankguard 2-3HP	27.50
HM8612	Crankguard 3-4HP, 4 1/4" Cyl. Bore	32.50
HM882	Crankguard 5-6HP	40.50
HM862	Exhaust Rocker Lever 2HP, 3HP with 3 3/4" Bore	39.75
HM8620	Exhaust Rocker Lever 3-4HP With 4 1/4" Bore	44.75

**WITTE "HEADTYPE" 1 1/2-7HP cont.**

HM8621	Exhaust Rocker Lever 5HP	46.75
HM8622	Exhaust Rocker Lever 7HP	53.10
HM8624	Exhaust Rocker Lever Shaft & Nut 2-4HP	19.25
HM8626	Exhaust Rocker Lever Shaft & Nut 5-6HP	22.25
HM862A	Exhaust Push Rod 2-3HP 3 3/4" Cyl Bore	22.75
HM862AA	Exhaust Push Rod 3-4HP 4 1/4" Cyl Bore	25.00
HM862B	Exhaust Push Rod 5HP	27.00
HM863	Fuel Tank 11" X 3" (Round) 2-4HP	47.50
HM864	Fuel Tank 13" X 3 1/2" (Round) 4-5HP	55.50
HM865	Gasket, Head 2-3HP	8.50
HM8651	Gasket, Head (4 1/4" Bore) 3-4HP	9.00
HM865A	Gasket, Head 5HP	10.50
HM865C	Gear, Crankshaft 1 1/2" I.D., 3-4HP	68.00
HM865F	Gear, Governor (with threads)	49.50
GR05	Grease Cup, Rod. 2-3HP	10.00
GR07	Grease Cup, Main, 2-3HP	14.00
GR08	Grease Cup, Main, 5HP	15.50
HM866	Magneto, Trip Rod 2-4HP	38.00
HM867	Magneto Timing Bushing (Retard Lever)	65.00
HM868	Muffler 2-4HP	22.25



HM868A	Muffler 5HP	26.75
HMR20	Piston Ring 3 1/4" X 1/4" 1 1/2HP	6.00ea
HMR31	Piston Ring, 3-3/4" X 1/4", 2-3HP	6.00ea
HMR37	Piston Ring, 4-1/4" X 1/4", 3-4HP	8.00ea
HMR47	Piston Ring, 5" X 5/16", 5-6HP	12.00ea
HM02	Sparkplug	5.00
HM870	Spring, Needle Valve 2-4HP	2.00
HM871	Spring, Speed Adjusting 2-5HP	3.75
HM872	Spring, Mag Armature Return 2-5HP	4.00
HM873	Spring, Mag Drive 2-5HP	4.00
HM873A	Spring, Timing Bushing	3.75
HM874	Spring, Exhaust Valve 2-4HP (5-6HP available)	4.75
HM875	Spring, Intake Valve 2-4HP (5-6HP available)	4.75
HM877	Valve, Exhaust 2-4HP	31.50
HM878	Valve, Exhaust 5-6HP	35.75
HM879	Valve, Intake 2-4HP	31.50
HM880	Valve, Intake 5-6HP	35.75

(Witte 7-8HP carb parts, ex. push rod, throttle rod, mag trip rod, misc. now available)

**WITTE "HEADLESS"**

Made from 1911-1922 these engines came in 1 1/2-22HP. Witte (some pronounce it Wit and other's Witty) provided owner's with a better than average instruction book, but their parts list along with lack of any ID on their castings leave something to be desired for today's part's dealers. While searching for parts we suggest checking with us every so often as we get new parts engines in. We have a fair supply of used parts for Witte.

L66	Instructions & Parts #14, 1 1/2-11HP	4.00
L66A	Instruction & Parts #19, 2-22HP	5.50
HM884	Carb (Mixer) Throttle Valve #67	18.50
HM885	Carb (Mixer) Check Valve Cage, 1/4", #76	20.50
HM8851	Carb (Mixer) Check Valve Dart, 1/4", #34	6.25
HM886	Carb (Mixer) Check Valve Cage, 3/8", #76	20.50
HM8861	Carb (Mixer) Check Valve Dart, 3/8", #34	6.25
HM8925	Crankguard, 2HP	27.50
HM8926	Crankguard, 3HP	32.50
HM863	Fuel Tank, 11" dia. X 3" Height	47.50
HM864	Fuel Tank, 13" dia. X 3 1/2" Height	55.50
HM894	Governor Blade, 2-6HP, #15	20.50
HM8942	Governor Latch #25	41.25
HM8945	Spark shift Lever 2-6HP	20.50
HM895	Spring, Exhaust, 2HP	4.75
HM8954	Spring, Intake, 2HP	5.75
HM897	Timer Contact Spring #27	16.75
HM898	Timer Spring Fiber Block #62	28.75
HM8985	Valve Cage Copper O-Ring 2HP	4.00
HM8987	Valve Cage Copper O-Ring 4HP	4.50
HM899	Valve, Exhaust 2HP	31.50
HM899A	Valve, Intake 2HP	31.50

(We have drawings for larger size valves)

## MISC ENGINE PARTS AND ACCESSORIES

### LUNKENHEIMER MIXER

The parts listed here are for the 1/2" & 3/4" mixer as shown at the right. The parts are the same for the right hand pattern (which this one is) and the left hand pattern (fuel line union is on opposite side). Beware of look-a-likes. If your mixer doesn't have Lunkenheimer printed on it and LH or RH it's not a Lunkenheimer and these parts probably won't fit.

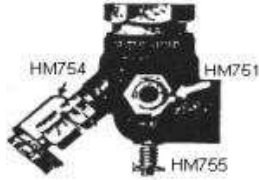

HM750	Brochure	1.00
HM751	Fuel Line Union & Nut (union takes 1/8" pipe)	33.25
HM752	Fuel Line Union & Nut (union takes 1/4" pipe) (Unions fit 1/2" and 3/4" Lunkenheimers)	33.25
HM753	Needle Valve-fits all sizes	29.50
HM754	Needle Valve Spring-fits all sizes	10.75
HM7542	Spring, Compensating valve	3.00
HM7545	Valve-Compensating, 1/2" mixer	35.75
HM755	Valve-Compensating, 3/4" mixer	35.75

### CRANKHANDLES (w/wood handle)

HM836	Crankhandle For 1" Crankshaft	44.50
HM8361	Crankhandle For 1 1/8" Crankshaft	44.50
HM8362	Crankhandle For 1 1/4" Crankshaft	44.50
HM8363	Crankhandle For 1 3/8" Crankshaft	44.50
HM8364	Crankhandle For 1 1/2" Crankshaft	44.50



(Crankhandles have wood handles that turn with your hand)

### MUFFLERS, CAST IRON

HM392	Muffler, cast iron ball, 5" dia. 3/4" to 1 1/4" NPT*	46.75
HM393	Muffler, cast iron ball, 7" dia. 1" to 1 1/2" NPT*	52.50
HM394	Muffler, cast iron ball, 9" dia. Up to 2 1/2" NPT*	99.75
HM395	Muffler, cast iron, Cone 6" dia. 1" to 1 1/4" NPT*	52.50



\*Please be specific on which size pipe thread you require.

### CAST IRON ENGINE PULLEYS

HM925	Pulley With Set Screw, 4" X 4", 1" Hole	75.00
HM9251	Pulley With Set Screw, 4" X 4", 1 1/8" Hole	75.00
HM9252	Pulley With Set Screw, 4" X 4", 1 1/4" Hole	75.00
HM9253	Pulley With Set Screw, 4" X 4", 1 3/8" Hole	75.00
HM9254	Pulley With Set Screw, 4" X 4", 1 1/2" Hole	75.00
HM926	Pulley W/Set Screw & Keyway, 4"X4", 1" Hole*	83.10
HM9261	Pulley W/Set Screw & Keyway, 4"X4", 1 1/8" Hole*	83.10
HM9262	Pulley W/Set Screw & Keyway, 4"X4", 1 1/4" Hole*	83.10
HM9263	Pulley W/Set Screw & Keyway, 4"X4", 1 3/8" Hole*	83.10
HM9264	Pulley W/Set Screw & Keyway, 4"X4", 1 1/2" Hole*	83.10

\*Please give width of keyway when ordering.

## HIT & MISS ENT. SHOW & SWAP

### TWO BIG DAYS- First Fri. & Sat. in June - Don't miss this!

We do this every year, and every year it gets a little bigger and better. On Friday our crew will be giving demonstrations on machining, pouring babbit, and magneto repair. Friday evening we'll have our "Gas Engine Seminar". Please bring your engine problems and questions to present to our panel of very knowledgeable gas engine men. If they can't help you're beyond help! Around 8:00PM our party gets going with some music and a cozy bonfire. Saturday morning brings new arrivals and the buying and selling goes hog wild! We'll have plenty of our crew and volunteer's to help you with your engine problems, so bring engines you need help with. Oh yes-no charge unless you need some parts.

We have lots of door prizes with drawings on the hour until 4PM Fri. & 2PM Sat. Folks who come in on Friday evening or sooner are eligible for the grand prize of a \$300.00 gift certificate from Hit & Miss. This drawing is shortly after 3PM Saturday and you must be present to win. We go all out for you and ask one little favor in return. You can bring all you want to exhibit, but please bring some items to sell. If nothing engine related is available primitive antiques, tools, shop items, etc. will do just fine (if questions please call). Y'all come now!

**FREE CAMPING-FREE SETUPS-COURTESY TENT-GOOD FOOD**

## PISTON RINGS

HMR025	2" X 3/16"	5.00
HMR03	2 1/4" X 1/8"	5.00
HMR04	2 1/4" X 1/8" (Oil)	7.00
HMR05	2 3/8" X 1/8"	5.00
HMR06	2 3/8" X 1/8" (Oil)	7.00
HMR09	2 1/2" X 3/16"	5.00
HMR10	2 3/4" X 1/8"	5.00
HMR026	2" X 3/16" (Oil)	7.00
HMR11	3" X 1/8"	6.00
HMR12	3" X 3/16"	6.00
HMR12A	3" X 3/16" (Oil)	7.00
HMR13	3" X 1/4"	6.00
HMR132	3" X 5/16"	6.00
HMR14	3 1/8" X 1/8"	6.00
HMR142	3 1/8" X 3/16"	6.00
HMR15	3 1/8" X 1/4"	6.00
HMR16	3 1/8" X 1/4" (Oil)	7.00
HMR17	3 1/4" X 1/8"	6.00
HMR18	3 1/4" X 3/16"	6.00
HMR19	3 1/4" X 3/16" (Oil)	7.00
HMR20	3 1/4" X 1/4"	6.00
HMR201	3 1/4" X 1/4" (Oil)	7.00
HMR205	3 3/8" X 3/16"	6.00
HMR21	3 1/2" X 1/8"	6.00
HMR22	3 1/2" X 3/16"	6.00
HMR225	3 1/2" X 3/16" (Oil)	7.00
HMR227	3 1/2" X 5/16"	6.00
HMR23	3 1/2" X 1/4"	6.00
HMR24	3 1/2" X 1/4" (Oil)	7.00
HMR25	3 5/8" X 1/8"	6.00
HMR26	3 5/8" X 1/8" (Oil)	7.00
HMR27	3 5/8" X 3/16"	6.00
HMR275	3 5/8" X 3/16" (Oil)	7.00
HMR28	3 5/8" X 1/4"	6.00
HMR29	3 3/4" X 1/8"	6.00
HMR30	3 3/4" X 3/16"	6.00
HMR31	3 3/4" X 1/4"	6.00
HMR315	3 3/4" X 5/16"	6.00
HMR32	4" X 1/8"	8.00
HMR325	4" X 3/16"	8.00
HMR33	4" X 1/4" (Oil)	10.50
HMR34	4" X 1/4"	8.00
HMR35	4" X 5/16"	8.00
HMR335	4" X 3/8"	8.00
HMR36	4 1/8" X 1/4"	8.00
HMR365	4 1/8" X 5/16"	8.00
HMR37	4 1/4" X 1/4"	8.00
HMR38	4 1/4" X 1/4" (Oil)	10.50
HMR39	4 1/4" X 5/16"	8.00
HMR40	4 1/4" X 3/8"	8.00
HMR415	4 1/2" X 5/32"	8.00
HMR416	4 1/2" X 3/16"	8.00
HMR42	4 1/2" X 1/4"	8.00
HMR43	4 1/2" X 5/16"	8.00
HMR45	4 1/2" X 3/8"	8.00
HMR455	4 5/8" X 3/8"	8.00
HMR457	4 3/4" X 3/16"	8.00
HMR458	4 3/4" X 1/4"	8.00
HMR459	4 3/4" X 1/4" (Oil)	10.50

**PISTON RINGS cont.**

HMR46	4 3/4" X 5/16"	8.00
HMR460	4 3/4" X 3/8"	8.00
HMR461	5" X 3/16"	12.00
HMR462	5" X 3/16" (Oil)	14.50
HMR463	5" X 1/4"	12.00
HMR47	5" X 5/16"	12.00
HMR48	5" X 3/8"	12.00
HMR485	5 1/4" X 1/4"	14.00
HMR49	5 1/4" X 3/8"	14.00
HMR50	5 1/2" X 5/16"	14.00
HMR502	5 1/2" X 3/8"	14.00
HMR505	5 1/2" X 1/2"	14.00
HMR515	5 3/4" X 3/16"	14.00
HMR52	5 3/4" X 3/8"	14.00
HMR525	6" X 3/8"	17.50
HMR526	6" X 5/16"	17.50
HMR527	6" X 1/2"	17.50
HMR528	6 1/2" X 5/16"	20.00
HMR53	6 1/2" X 3/8"	20.00
HMR54	6 1/2" X 1/2"	20.50

**STEAM cont.**

**PRESSURE GAUGES**



Pressure Gauge

ST32560	Pressure Gauge, 2 1/2" face, 60 lbs.	25.50
ST325100	Pressure Gauge, 2 1/2" face, 100 lbs.	25.50
ST325160	Pressure Gauge, 2 1/2" face, 160 lbs.	25.50
ST325200	Pressure Gauge, 2 1/2" face, 200 lbs.	25.50
ST330160	Pressure Gauge, 3 1/2" face, 160 lbs.	42.00
ST330200	Pressure Gauge, 3 1/2" face, 200 lbs.	42.00
ST330300	Pressure Gauge, 3 1/2" face, 300 lbs.	44.00

**SIPHONS**



Siphon



Angle Siphon

ST331	Siphon 1/4" NPT, black iron	12.75
ST332	Siphon 1/4" NPT, brass	20.25
ST333	Siphon 1/4" NPT, iron, angle	12.75

**TRICOCKS**

ST430	Tricock 3/8" 125 lbs WSP (polished brass)	52.50
ST435	Tricock 1/2" short shank, 250 lbs. WSP	25.50



Tricock

ST4355	Tricock 1/2" long shank, 250 lbs WSP	26.75
--------	--------------------------------------	-------

**VALVES**



Angle Valve

ST436	Valve, Angle w/brass disc, 1/4"	24.50
ST4361	Valve, Angle w/brass disc 3/8"	30.00
ST4362	Valve, Angle w/brass disc, 1/2"	30.00

ST437	Valve, Check, disk type, Globe style, 1/4"	30.00
ST4370	Valve, Check, w/ball (fuel, in-line), 1/4"	26.00
ST4371	Valve, Check, disk type, Globe style 3/8"	30.00



Angle Check Valve

ST4366	Valve, Check, Angle style with disc, 1/4"	28.00
--------	---	-------



Globe Valve

ST4374	Valve, Globe w/brass disc, 1/4"	23.50
ST4375	Valve, Globe w/brass disc 3/8"	34.50
ST4376	Valve, Globe w/brass disc, 1/2"	34.50

**STEAM**

**FLUE BRUSHES**

Flue brushes are single spiral. Handles and double spiral, stainless steel, brass and extra heavy-duty brushes are available.



Flue Brush-Single Spiral

ST200	Flue Brush, 3/4" dia.	14.00
ST201	Flue Brush, 1" Dia.	14.00
ST202	Flue Brush, 1 1/4" dia.	14.00
ST203	Flue Brush, 1 1/2" dia.	14.00
ST204	Flue Brush, 1 3/4" dia.	14.00
ST205	Flue Brush, 2" Dia.	14.00
ST206	Flue Brush, 2 1/4" dia.	16.00
ST207	Flue Brush, 2 1/2" dia.	17.50
ST208	Flue Brush, 3" Dia.	20.00

**FLUE SCRAPERS**

Flat tempered steel wire construction



Scraper, Flat Tempered Steel

ST221	Flue Scraper, Flat Temp. Steel Wire, 1 1/4"	26.00
ST222	Flue Scraper, Flat Temp. Steel Wire, 1 1/2"	26.00
ST223	Flue Scraper, Flat Temp. Steel Wire, 1 3/4"	27.50
ST224	Flue Scraper, Flat Temp. Steel Wire, 2"	27.50
ST225	Flue Scraper, Flat Temp. Steel Wire, 2 1/4"	27.50
ST226	Flue Scraper, Flat Temp. Steel Wire, 2 1/2"	28.50
ST227	Flue Scraper, Flat Temp. Steel Wire, 3"	29.50



Elliptical Scraper

ST229	Flue Scraper, Elliptical, 1 1/2"	57.50
ST300	Flue Scraper, Elliptical, 1 3/4"	57.50
ST301	Flue Scraper, Elliptical, 2"	60.50
ST302	Flue Scraper, Elliptical, 2 1/4"	60.50
ST303	Flue Scraper, Elliptical, 2 1/2"	62.00
ST304	Flue Scraper, Elliptical, 2 3/4"	65.00

**STEAM cont.**

ST438	Valve, Needle (Metering) 1/8"	28.00
ST4381	Valve, Needle (Metering), 1/4"	28.00
ST4385	Valve, Needle (Metering), Angle 1/8"	34.00
ST4386	Valve, Needle (Metering), Angle 1/4"	34.00
ST4389	Water Gauge (set), 3/8" 125 lbs WSP	72.50
ST439	Water Gauge (set), 1/2", 250 lbs. WSP	57.00
ST400	Whistle Valve With Handle, 1/4"NPT	65.00
ST401	Whistle Valve With Handle, 3/8"NPT	71.00
ST402	Whistle Valve With Handle, 1/2"NPT	77.50
ST403	Whistle Valve With Handle, 3/4"NPT	125.00
ST404	Whistle Valve With Handle, 1"NPT	165.00
ST410	Whistle Valve Handle, Cast Iron, 7" length.	14.00
ST411	Whistle Valve Handle, Cast Iron, 9 5/8"	16.00



**LITERATURE cont.**

LS27	EDWARD ENGINE, I&P (All Models) Bosch Mag. Inst.	2.50
LS28	EMERSON BRANTINGTON-No. 287 "EB" 1 1/2HP, I&P	2.00
LS29	EMERSON BRANTINGTON-Type "S" 2 1/2HP, I&P	1.50
L09	FAIRBANKS-MORSE SERIAL NO. LIST	.50
L16	F/M-1 1/2HP "Headless"-Inst. No. 240C, I&P	3.00
L165	F/M 3-6HP T/G, W/Sump Rotary Mag (Ignitor Model) I&P	5.00
L17	F/M-3-6HP T/G, W/Sump. Oscill. Mag (Ignitor) I&P	4.00
L18	F/M-10-15HP- W/Sump. Oscill. Mag "1914-18" Parts	7.50
L185	F/M-1 1/2HP-T/G-"1919 Model" I&P	5.50
L15	F/M-1 1/2-6HP W/Bosch Mag (5 1/4" Trip Arm) I&P	4.00
L151	F/M-1 1/2-6HP Bosch, 2 3/4" Trip, I&P	4.50
L19	F/M-10,15 & 20HP-Model "ZA" W/Bosch Mag-Parts	4.00
L20	F/M-1 1/2 & 3HP-Battery Equipped- I&P	2.50
L14	F/M-2, 3 & 6HP-T/G, W/"R, RV, or J" Rotary Mag, I&P	4.00
L191	F/M-10, 15 & 20HP-Model"ZA" W/"R, RV or J" Mag-Parts	4.00
LS51	F/M-2, 3 & 6HP, W/"R" Mag, Sales Catalog	5.00
L090	F/M-5-7HP-Style "B", I&P	2.00
L10	F/M-3HP-Style "C", I&P	2.00
L101	F/M "ZC" 3HP & "52" I&P	6.00
L11	F/M-"ZC"-Model #118-208-503-739-7-36HP, I&P	9.50
L12	F/M-Style "D"-1 1/2HP I&P	2.00
L13	F/M-Style "D"-2HP, I&P	2.00
L135	F/M-Style "D"-1 1/2-2HP-No. R2763, Parts	6.50
LS30	F/M-BULLDOG Catalog No. 1081	6.00
LS32	F/M-No.1 Eclipse No. 2204G-Set Up&Oper., Parts	2.50
LS33	F/M "F" 40 Light Plant No. 2552A-W/Bosch Equip. Eng.-Instructions Only	1.50
LS41	F/M "H"-Jack Jr. 2, 4 & 6HP-Horiz., I&P	3.00
LS34	F/M-Type "H" & "T" Engine-Sales Catalog	10.50
LS46	F/M-Type "H" & "T" Eng.-Catalog No. 80G	4.50
LS35	F/M-No. 2072 "T" Vert., 1-12HP, Set-up & Oper.	3.00
LS44	F/M "Y"-Oper. & Construction No. 1031	10.50
LS47	F/M "Y"-No. 2639-10 & 15HP-W/Side Injection 20 & 25HP W/Center Injection	6.00
LS48	F/M "Y" Horiz.-Inst. No. 39001-10 & 15HP "Y" W/Side Injection-20 & 25HP W/Center Injection Installing & Operation	7.50
LS31	F/M "Y" Horiz.-Bulletin No. 1000-Styles "H" & "HB"-10-25HP	6.00
LS50	F/M-Model 32-E Bulletin No. 1000-Styles "H" Stationary Service	7.50
LS49	F/M-Inst. No. 3200D-Stationary Diesel Engine Models 32D12-1, 2, & 3 Cylinder-32E14-1, 2, 3, 4, 5, 6 Cylinder	24.00
LS42	F/M-"VA" Diesel Eng.-Operation & Construction	9.50
LS37	F/M "H"-1-2 Stage Air Compressors-No. 2888A Install. & Oper.	2.00
LS38	F/M-No. 1800 Direct Current Motors & Generators	2.50
LS43	F/M MOTOR CARS-No. 57,757, V757, 57B, & 757B-Parts	10.50
L201	FAIRMONT RAILWAY MOTORS, PH-4HP, OH-6HP, Inst.	7.00
L202	FAIRMONT RAILWAY MOTORS-4HP Class M9, I&P	5.00
L203	FAIRMONT RAILWAY MOTOR CAR-All Types-I&P	6.50
LS53	FAIRMONT INSPECTION CARS, M19 Series "F", I&P	17.50
LS54	FAIRMONT-4HP Inspection Car Engine, Parts	2.00
LS55	FIELD FORCE PUMP CATALOG 34	7.50
L204	FOOS CATALOG NO. 12	8.50
L205	FOOS CATALOG NO. 22	9.00
L206	FOOS GAS & GASOLINE ENGINES, I&P, 1900	6.50
L207	FOOS JR. NO 601 I&P	4.00
LS56	FRANKLIN Valveless Type, OFC & OGC, I&P	10.50
L21	FULLER & JOHNSON-"NC"-1 1/2-2 1/2HP, I&P	1.50
L22	FULLER & JOHNSON PUMP ENGINE, I&P	3.00
L220	FULLER & JOHNSON SERIAL NO. LIST	.50
LS57	FULLER & JOHNSON "N"-1 1/2-10HP, Adv. Brochure	4.00
L225	FULLER & JOHNSON "N"-3, 5, 7, 9, 12HP, I&P	4.00
LS58	FULLER & JOHNSON "NB"-1 1/2-12HP Adv. Brochure	1.50
LS59	FULLER & JOHNSON "NB"-3HP-Operating, I&P 1926	2.00
LS60	FULLER & JOHNSON Diaphragm Pump, Bulletin	1.00
LS61	FULLER & JOHNSON "ND", 2-3 1/2HP "1930" I&P	1.50
LS62	FULLER & JOHNSON-Farm Pump Eng., Catalog #17A	9.50
LS63	FULLER & JOHNSON-Farm Pump Engine-"1933"-Parts	1.50
LS64	FULLER & JOHNSON Pressure Pump Outfits-Adv.	1.00
LS642	F & J #605-Pump Engine With Force Pump, Adv.	1.00

**LITERATURE**

**PLEASE READ BEFORE ORDERING**

Most of these copies are good or better, but there are a few that may be considered only passable, the fault being in shop wear, age, etc. in the originals. They do make an excellent reference book that you don't mind getting a little grease on. Copies are sold for reference purposes only and are not refundable (Exceptions-copied incorrectly or our mistake in order).

Abbrev. I=Instructions; P=Parts

L005	AERMOTOR "8" Cycle-Setting Up and Operating	1.00
LS2	AERMOTOR-"For Pumping And Power"-Catalog	3.00
LS3	ACADIA-2 Cycle-I & P	6.00
LS4	ALAMO WOOD SAWING OUTFITS-9-15HP, 3-6HP Adv.	2.00
LS5	ALAMO ELECTRICAL LIGHT PLANT PAMPHLET	1.00
L08	ALAMO-EMPIRE-1-16HP-I&P	6.00
L01	ALPHA-DELAVAL-1 1/2-3HP W/WICO EK Mag, I&P	2.50
LS7	ALPHA-DELAVAL-Junior Cream Separator-Inst.	2.00
LS8	ALPHA-DELAVAL-Senior 2 Cyl. No. D-600, I&P	4.00
L02	ASSOCIATED-Gas 1 1/2-18HP, I&P	6.00
L025	BABBITT BEARING ADVICE PAMPHLET	2.00
L028	BEAN 4 & 6HP I&P	5.00
LS11	BRANDFORD "CUB"-Operating Instruction	2.00
L03	BESSEMER-5-165HP-"1915"-Inst. Manual	15.00
LS12	BESSEMER-Vert.-2-10HP-Advertising Pamphlet	2.50
LS13	BRIGG'S & STRATTON-Models N Series, Parts Book	9.00
L04	BRIGG'S & STRATTON-Tune Up & Instructions (Models A-Z Parts and Lots of Illustrations)	14.50
LS14	BRIGG'S & STRATTON-Model 6S-I&P	5.50
LS15	BRIGG'S & STRATTON-Model "FH"-Inst.	5.50
LS159	BUDA "HIVELO" ENG.-H, J, K, L Series, Inst. Manual	5.50
LS16	BUDA "HIVELO" ENG.-H, J, HP, K, L, LO, M-Inst. Manual	5.50
LS165	Bulldog Engines #1081, 1922 I&P	6.00
LS17	BURKETT KEROSENE ENGINE-Sales Catalog	2.50
LS18	COOK MOTOR CO. Single & Double Cyl. -Inst.	8.00
LS19	COLDWELL "Cub" 21-"L"-Jr. 25 Lawn Mower & Eng.	4.00
L05	CUSHMAN-Vertical "C" 4HP, I&P	5.00
L051	CUSHMAN-Type "C"-4-8HP, Instructions	3.00
L052	CUSHMAN FARM ENGINE PAMPHLET-Type "C"-4-8HP	1.50
L06	CUSHMAN "CUB"-Model "R" 2-4HP, I&P	2.50
L061	CUSHMAN "R" CUB-R2-R40, I&P	3.00
L063	CUSHMAN "X" -Battery Or Wico "EK", I&P	2.50
LS21	CUSHMAN-"Air Cooled"-Model M6-7-8-9 (Maint.)	2.00
L07	DELCO LIGHT-32 Volt, I&P	3.50
L070	DELCO LIGHT-Model 850-Parts Catalog	10.00
L071	DELCO LIGHT-Model 1250-1271-1275-301-31-312 (Parts Only)	17.00
L072	DELCO LIGHT-Wiring Info. -Lots of Diagrams	18.00
L073	DELCO LIGHT-Mechanical, Shop Manual	4.00
L074	DELCO LIGHT-7KXG-KXG-13, KXR-7, KXR-13-Batteries	5.00
LS22	DELCO LIGHT PLANT AUTO.BAT.CHARGING UNIT	1.00
LS23	DEMSTER GASOLINE ENGINE, Tank Cooled, Catalog	3.00
L075	DETROIT STATIONARY-Instructions	3.50
LS24	DETROIT LUBRICATOR-Bulletin 55A	2.00
LS25	DOMESTIC "F"-Operation & Inst.	2.00
LS26	THE EASY ENGINE-4 Cycle-"Air Cooled"-Inst.	2.00
L076	ECONOMY-Models D, E, F, G, H, N, & S I&P	4.00
L079	ECONOMY SPARTA-Inst.	5.50

**LITERATURE cont.**

L23	GALLOWAY-1 3/4 & 2 1/4HP, I&P	4.50
L24	GALLOWAY-5, 7, 9, 12, & 16HP, I&P	4.50
LS65	1. The Selection and Use of Magnet Charging & Treating Equip. 2. Hall Effects Gaussmeters 3. Complete Systems Approach	8.50
LS651	GRAY 4 CYCLE STATIONARY-Models G2 & M-Parts	1.00
LS66	HANCOCK INSPIRATORS-Stationary Type "A", I&P	1.00
L25	HERCULES-1 1/2-12HP, W/Wico "EK" & Webster Mags (New & Old Style Magneto Set Up), 64 Pages, I&P	9.00
L251	HERCULES-"XI"- "XK"-1 3/4-8HP, I&P	8.50
L26	HERCULES-"XI"- "XK"-1 3/4-8HP, Parts	6.00
L265	HERCULES-"JK"-1 1/2-2 HP I&P	3.50
L266	HERCULES-"JK"-2 1/2-3 1/2HP, I&P	3.50
L27	HERCULES-"JT"- "JK"-1 1/2-3 1/2HP, Parts	3.50
L270	HERCULES HISTORY by GLEN KARCH	10.00
L271	HERCULES SERIAL NO. LIST	1.00
LS68	HERCULES 1 3/4-8HP "XK", 1930 Eng. Price List	1.00
LS70	HERCULES 1 1/2-12HP "EW" (Early Model), Inst.	6.00
LS71	HERCULES SALES LEAFLET-"JI-JK"	1.00
L28	IDEAL "R" Eng. & Mower-(Rect. C/C Cover) I&P	4.00
L280	IDEAL "R"-(Round Crankcase Cover) I&P	4.00
L37	IHC-TITAN JR.-Hopper Cooled-1HP, I&P	3.00
L35	IHC-TITAN FAMOUS-1HP-Hopper Cooled, I&P	1.50
L36	IHC TOM THUMB-1HP-(Air Cooled), I&P	1.50
LS76	IHC HORIZ.-H/C-T/G-Stationary & Portable, I&P	5.00
L335	IHC TITAN HORIZONTAL- 4-25HP-I&P	6.00
LS77	IHC TITAN OIL ENG. CATALOG	12.50
L380	IHC VERTICAL.-Tank Cooled Eng.-Sales Catalog	15.00
LS72	IHC FAMOUS Vert., 2HP Jr.-6HP, I&P	4.50
L381	IHC MOGUL-1, 1 3/4, & 2 1/2HP, I&P	3.50
LS74	IHC MOGUL OIL ENGINE CATALOG-1-50HP	10.50
L325	IHC "M" 1 1/2-6HP "Ignitor Model" (2 needle carb) I&P	6.50
L33	IHC "M" 1 1/2-6HP "Ignitor Model" (3 needle carb) I&P	6.00
L333	IHC "M"-10HP-Ignitor Model, I&P	5.50
L31	IHC McCORMICK-DEERING-1 1/2-6HP W/Wico EK, I&P	7.00
L32	IHC McCOR.-DEERING-w/Wico "EK" Mag.-Shop Manual	9.50
L287	IHC TYPE "L"-1 1/2HP-Parts Only	5.00
L289	IHC "LA" 1 1/2-2 1/2HP, W/Wico "H" Mag, I&P	3.00
L29	IHC McCORMICK-DEERING "LA"-1 1/2-5HP-I&P	3.00
<b>**Recommend ordering L30 with "LA" manuals for exc. part's breakdown</b>		
L30	IHC "LB" 1 1/2-5HP, I&P	8.00
LS73	IHC "LB"-Radiator Cooled-3-5HP, I&P	5.50
L38	IHC SERIAL NO. LIST	.50

**The Single Cylinder Gas Engine by F. B. Wright  
L551-\$5.50**

**"You can't beat this book for learning the basics of working on single cylinder engines. Highly recommended for the novice."**

LS791	IMPERIAL GASOLINE ENG. CATALOG	5.00
L382	IOWA (Associated)-Oversized Engines 2-18HP, I & P	4.50
L39	JOHN DEERE Type "E"-1 1/2-6HP, I&P	3.50
L391	JOHN DEERE SERIAL NO. LIST	.50
LS80	JAEGER "H" ENGINE-2-8HP, I&P	8.50
LS81	JACOBSON JR. Jack Gas Engine, I&P	2.00
LS82	JACOBSON "STANDARD" ENGINE-2 1/2-16HP, Parts	2.00
LS83	JOHNSON IRON HORSE-X200 & X300 Series-Parts	2.00
LS84	KOHLER CATALOG-Shows "K" and others	7.50
LS85	KOHLER Electrical Plant "K" Series, I&P	16.00
L392	LAUSON & FROST KING-"1916", I&P	4.00
LS87	LAUSON & FROST KING CATALOG-"1916"	8.00
LS88	LEROI-No. 106928-Model "YP"-1, 2 Cycle-Parts	4.50
LS89	LEROI ENGINE & COMPRESSORS-Model 3-5, I&P	8.50
LS90	LEROI Care & Operation "L" Head	5.50
LS91	LEROI-Correct Lubrication of Leroi Engines	3.00
LS92	LEROI-Parts & Inst. On Models GL-2H, GL-4 Magnetos	4.50
LS93	LEROI "L" Heads-Bulletin No. 300 Sizes-Specs.	4.50
LS94	LEROI-Zenith Carburetor "L" Head Eng., I&P	3.50
LS96	MADISON-KIPP LUBRICATOR-Model 50, I&P	2.50
L012	MAGNETO-AMERICAN BOSCH AB-33, I&P	2.00
L390	MAGNETO-JOHN DEERE-Service Man.-Mag. & Ignitor	2.00

**LITERATURE cont.**

L40	MAGNETO-IHC "M-Type 1 1/2-10HP, Care & Oper., Parts	5.00
L41	MAGNETO-IHC-"LB"- "H-1" I&P	6.50
L42	MAGNETO-WEBSTER "Old Style"-Helps & Hints	2.50
L423	MAGNETO-Numerical List of Ign. Bracket Assy.	2.50
L425	MAGNETO-"WEBSTER" Engine Manufacturer's List	2.00
L43	MAGNETO-Wico "EK", I&P	3.00
LS143	MAGNETO-Wico "EK"-Trouble Shooting-Inst.	1.50
L44	MAGNETO-Wico "H & AH", I&P	2.50
L440	MAJESTIC 3-14HP, I&P	3.50
L441	MARINE ENGINE-Two Cycle-Care & Operation	2.00
LS97	MASSEY-HARRIS No. 2 Kerosene-Parts List	8.00
LS98	MAYNARD ADVERTISING (From Chas. Williams Dept)	2.50
L45	MAYTAG INSTRUCTION MANUAL, Vert.-82-92-Twin	4.00
LS100	McCORD-CLASS "B" Force Feed Lubricator-Inst.	3.00
LS101	METROPOLITAN INJECTORS-HD-Ejectors Catalog	9.00
L46	MONITOR GASOLINE ENGINES CATALOG #45	12.00
L465	MONITOR GASOLINE ENGINES CATALOG #51E	9.50
LS102	MONITOR Horizontal-8-15HP, I&P	2.00
LS103	MONITOR REPAIR CATALOG NO. 58-Parts Only	2.00
LS104	MONITOR ENGINE- 1 1/4-8HP-Operating Inst.	3.50
LS105	MOON TURBINE GENERATOR FLYER	.50
L47	NELSON BROS JUMBO 1 3/4-7HP W/Webster, I&P	4.00
L475	NELSON BROS JUMBO LINE, 1 1/2-6HP, Early, I&P	2.50
L48	NELSON BROTHERS-Kero 3-12HP W/Webster Mag. I&P	4.00
L482	NELSON BROS 1 3/4-2HP, Model "U" with EK Mag I&P	6.00
L480	NEW HOLLAND-Operation & Inst.	5.00
LS108	NEW WAY "BH-FH-3" 3-5HP, Air-Cooled, Sales	2.50
LS1082	NOVO "AG" One Cyl. 2-3HP, Rad. or Hopper Cooled, Specs	1.50
LS1085	NOVO "A-16" Husky 2HP Specs.	1.00
L49	NOVO "S"-1 1/2-10HP-Operating Inst.	5.00
L491	NOVO-Model "S"-Kero & Gas-1 1/2- 10 HP Parts	6.00
L492	NOVO Model "S" Specs.	1.00
LS109	NOVO ROLLR One Cylinder "SU-GU-KU-TU" I&P	5.00
L490	NOVO ROLLR "U" One Cyl. Parts Only	6.50
LS1092	NOVO ROLLR One Cylinder 3-5HP Specs.	1.50
LS1093	NOVO ROLLR Two Cylinder "UF-HU-RU-YU" I&P	9.00
LS1094	NOVO Two & Four Cyl. "YF-AF-NF-EF" Inst.	6.00
LS1095	NOVO Four Cyl. "AF-NF-EF" Parts Only	7.50
LS1096	NOVO Two Cyl. "RF" Rad. or Hopper Cooled, Inst.	4.00
LS1097	NOVO "F" Two & Four Cyl. Specs. & Sales Catalog	6.00
LS1098	NOVO Air Compressor Outfits, Bulletin #153	4.00
LS1099	NOVO Hoisting Outfits, Bulletin #11	3.00
LS110	OHIO GAS ENGINE-4-50HP-Brochure	2.50
LS112	OLDS-Type "A"-Catalog	3.50
LS113	OLIN-5HP-Hopper Cooled-Advertisement	1.50
LS114	ORR & SEMBOWER Class "F" Marine-Bulletin	1.50
L52	OTTAWA LOG SAW-4-5HP, I&P	2.50
L53	OTTAWA LOG & TREE SAW-2HP, I&P	2.00
L535	OTTAWA ENCYCLOPEDIA-Log Saw Engine	8.50
L54	REID OILFIELD ENGINES-6-40HP, I&P, Misc., etc.	10.50
L55	REID OILFIELD ENGINES-Type "A"- "1930" I&P	12.00
LS116	RIFE HYDRAULIC RAM-Inst.	4.50
L550	SANDWICH 2, 3, 4 1/2, Light 6, Big 6, 8, & 10, Parts	5.00
LS117	SANDWICH ENGINE CO. "Cub" 1 1/2HP "1942" Parts	3.00
L56	SATTLEY (RACINE) FIELD BRUNDAGE-1 1/2-15HP, I&P	3.00
L57	"NEW" SATTLEY-1 1/2-(Solid Flywheel) I&P	4.00

**STEMGAS STEAM & SHOW DIRECTORY**

**L67 Call for current price.**

LS118	SATTLEY KERO ENGINE AD	1.00
L570	SCHMIDT'S CHILLED CYLINDER-Type "H"-3HP-Inst.	4.00
LS40	SHEFFIELD 57 MOTOR CAR-Eclipse 757, Inst.	4.00
LS119	SIMPLEX GAS ENGINE PARTS 10-35HP	4.00
LS120	SKINNER Steam Engine, Erect. & Maintenance	18.00
LS121	STANDARD-(NELSON BROS.)-3, 5, 7, & 10HP, I&P	4.50
L571	STA-RITE OR LA CROSSE, I&P	2.00
LS122	STERLING DOLPHIN-Stationary & Industrial, I&P	14.00
LS123	STEAM-Corliss Valve Gear-Instructions Only	1.00
LS125	STICKNEY-Horizontal Engines-3-6HP-Inst.	2.50
L58	STOVER CT-1, 2, 3, 4, I&P	4.50
L580	STOVER CT-1, I&P	3.50
L581	STOVER CT-2, I&P	3.50

**LITERATURE cont.**

L59	STOVER CT-3, I&P	3.50
L60	STOVER CT-4, I&P	3.00
L62	STOVER "K"-2HP-"KA" On Nameplate, I&P	4.00
L63	STOVER "KB"-1 1/2HP-"1936"-W/WICO EK, I&P	2.50
L64	STOVER "K"-1 1/2HP-"1936"-W/KE On Plate, I&P	2.00
L640	STOVER "K"-1 1/2HP-"1918"-H/C-Parts	2.00
L641	STOVER "Y"-2HP-"1931"-Horiz.-H/C-Parts	2.00
L642	STOVER SERIAL NUMBER LIST	.50
LS126	STOVER-Model CT & "K"-Catalog	1.50
LS127	STOVER DV1 & DV2-Vertical "1935", I&P	3.00
LS128	STOVER ECONOMY-3 1/2HP-CT3, I&P	2.50
LS129	STOVER-3HP-Horizontal-H/C-"1921"-Parts List	1.00
LS130	STOVER-3HP-Type "K"-W/"KB" On Tag, I&P	3.50
LS131	STOVER-6HP-Type "K"-W/"KC" On Tag, I&P	3.50
LS132	STOVER-8HP-Type "K"-W/"KD" On Tag, I&P	3.50
LS134	STOVER-3HP-Type "K"-W/"KF" On Tag, I&P	3.00
LS135	STOVER-4HP-Type "K"-W/"K" On Tag, I&P	3.50
LS136	STOVER-Horiz.-H/C-2 1/2-14HP, Part's Only	2.00
LS137	STOVER-MV-2, MV-5, MV-6, MV-7, Vert.-"1940", I&P	8.00
LS1371	STOVER-6-40HP "1934"-Horizontal, Parts	3.50
L643	TAYLOR VACCUM-Cooled-Type "C"-Sales Pamphlet	1.00
L6433	TAYLOR VACCUM-"1929"-Parts List	2.00
L6434	TAYLOR VACCUM ENGINE-Ignitor Model I&P	4.00
L645	UNITED-Type "A"-1 1/2-15HP, I&P	4.00
L646	WATERLOO BOY GASOLINE ENGINE-2-14HP, I&P	3.50
LS139	WATER POWER ON THE FARM-Chapter 16	2.00
LS140	WAUKESHA 6 CYLINDER ENGINE-"1936" Oper. & Care	4.50
LS141	WEBER HORIZONTAL-Type 5 NDL, 14" X 14", Parts	3.50
LS142	WEBER-Type 3BM-11" X 14"-Horiz. Parts	3.50
LS143	WICO-"EK" Trouble Shooting-Inst. Only	1.50
L65	WITTE NO. 20-"Headtype"-2-25HP, I&P	4.00
L66	WITTE NO. 14-"Headless"-1 1/2-11HP, I&P	4.00
L66A	WITTE NO. 19-"Headless" 2-22HP-Set up & Oper.	5.50
L660	WITTE SERIAL NO. LIST	.50
LS1455	WITTE-Advertising Brochure	2.00
LS146	WITTE "Headtype" Catalog, 2-30HP	11.50
LS1465	WITE "Headtype" Sales Catalog, 2-25HP	7.50
LS147	WITTE-T/G-Type F & H-No. FH-30-2-30HP-Parts	2.00
LS148	WITTE DIESEL & DIESELECTRIC ENGINES 5-10HP	5.00
L661	WORTHINGTON STEAM PUMPS-Specs & Parts	4.00

**BROCHURES - 1.00 ea.**

BR01	Hydraulic Ram. Deming
BR02	Hydraulic Ram. Rife
BR03	Lunkenheimer Mixers
BR04	Lunkenheimer Brass-(Pictures)
BR05	Penberthy Injectors
BR06	Madison-Kipp Lubricators
BR09	How To Secure Economical Motor Ignition

**ENGINE ACCESSORIES & HARDWARE**



P01	Babbitt, General Purpose, 1 lb.	7.00
P012	Babbittite "Damming Compound" 1 lb.	5.75
P015	Tintite, "Babbitt Flux"- 1/2 oz	3.00
L025	Babbiting Advice Pamphlet	2.00
P02	Brass Mesh Wire, 4" X 4" Fuel Filter, Etc.	5.50

**DRAINCOCKS**

(Machined brass with polished look-NICE)



HME11	Lever Handle, Plain 1/8"	9.85
HME12	Lever Handle, W/Hex Shoulder 1/8"	10.50
HME13	Lever Handle W/Hex & Curved Spout 1/8"	13.50

**ENGINE ACCESSORIES & HARDWARE cont.**



HME14	T-Handle, Plain 1/8"	9.75
HME15	T-Handle W/Hex Shoulder 1/8"	10.50
HME16	T-Handle W/Hex & Curved Spout 1/8"	13.25



HME17	Lever Handle, Plain 1/4"	10.50
HME18	Lever Handle W/Hex Shoulder 1/4"	10.75
HME19	Lever Handle W/Hex & Curved Spout 1/4"	14.00
HME20	T-Handle, Plain 1/4"	10.50
HME21	T-Handle W/Hex Shoulder 1/4"	10.75
HME22	T-Handle W/Hex & Curved Spout 1/4"	14.00
HME23	Lever Handle, Plain 3/8"	11.00
HME24	Lever Handle W/Curved Spout 3/8"	15.25
HME25	T-Handle 3/8"	10.50
HME26	T-Handle W/Curved Spout 3/8"	15.25
HME27	Lever Handle 1/2"	12.75
HME28	Lever Handle W/Curved Spout 1/2"	16.25
HME29	T-Handle 1/2"	11.50
HME30	T-Handle W/Curved Spout 1/2"	15.25
HME31	Lever Handle 3/4"	17.50

**FUEL LINE CHECK VALVES**

P05	Fuel Line Check Valve for 1/8" Tubing	4.50
P06	Fuel Line Check Valve for 3/16" Tubing	4.50
P07	Fuel Line Check Valve for 1/4" Tubing	4.50
P09	Fuel Line Check Valve for 5/16" Tubing	4.50
HM855	Fuel Line Check Valve For 1/8" Pipe	14.00

*Above check valves are for in-tank use-others available, see page 32*

**FUEL PUMP ACCESSORIES**

P08	Fuel Pump Packing, 1/8" Graphite (per ft.)	2.50
P10	Fuel Pump Diaphragm Material 6" X 6"	8.50

**FUEL TANK ACCESSORIES**

P110	Fuel Tank Neck & Cap, 1"	1.50
P111	Fuel Tank Neck & Cap, 1 1/4"	1.50
P112	Fuel Tank Neck & Cap, 1 3/4"	1.75
P113	Fuel Tank Neck & Cap, 2"	2.00

**GASKET MATERIAL/COPPER O-RINGS**

P12	Gasket Material, 11 1/2" X 11 1/2"	9.00
	For Heads & Igniters, Etc., Larger sizes available	
P130	Gasket Material, Cork 12" X 12"	4.00
HM7765	O-Ring, Copper, 1 3/4" X 2"	4.00

**GREASE CUP, AUTOMATIC, MACHINED BRASS**



HME36	Grease Cup, Auto. #00-1" ID X 1/8" PT	52.00
HME37	Grease Cup, Auto. #1-1 1/2" ID X 1/4" PT	62.50

**GREASE CUPS - MANUAL**



GR03	Grease Cup, Steel, 13/16" dia. X 1/8" PT	7.50
GR04	Grease Cup, Steel, 1" dia. X 1/8" PT	9.50
GR05	Grease Cup, Steel, 1" dia. X 1/4" PT	11.00
GR06	Grease Cup, Steel, 1 1/4" dia. X 1/8" PT	15.00
GR07	Grease Cup, Steel, 1 1/4" dia. X 1/4" PT	15.00
GR08	Grease Cup, Steel, 1 1/2" dia. X 1/4" PT	16.50

**ENGINE ACCESSORIES & HARDWARE cont.**

**GIB KEYS**

K201	3/16" X 1 1/2"	4.50
K203	3/16" X 2"	4.50
K204	3/16" X 3"	4.50
K205	1/4" X 1 1/2"	4.50
K206	1/4" X 2"	4.50
K207	1/4" X 2 1/2"	4.50
K208	1/4" X 3"	4.50
K210	5/16" X 2"	5.00
K211	5/16" X 2 1/2"	5.00
K212	5/16" X 3"	5.00
K213	3/8" X 1 1/2"	5.50
K214	3/8" X 2"	5.50
K215	3/8" X 2 1/2"	5.50
K216	3/8" X 3"	5.75
K217	3/8" X 3 1/2"	5.75
K219	3/8" X 4"	5.75
K220	3/8" X 4 1/2"	5.75
K221	3/8" X 5"	5.75
K222	7/16" X 3"	7.75
K223	7/16" X 3 1/2"	7.75
K2235	7/16" X 4"	8.50
K224	7/16" X 4 1/2"	8.50
K225	1/2" X 2"	6.50
K227	1/2" X 2 1/2"	6.50
K228	1/2" X 3"	6.50
K229	1/2" X 3 1/2"	7.75
K230	1/2" X 4"	7.75
K231	1/2" X 4 1/2"	7.75
K232	1/2" X 5"	7.75
K233	1/2" X 5 1/2"	8.50
K234	1/2" X 6"	8.50



For Stover & John Deere keys see Stover & JD parts list. These keys are not standard height-we machine to size.

**K200 GIB KEY PULLER \$28.50**

Length 14" Thickness 5/16" Hardened for years of Service. Our original puller in use for 25 years.

**ESSEX**

**Gas Engine Oilers**

Machined brass with Checkball and relief tube



**OILERS**

HME41	Oiler #1, 1/2-1 3/4" dia. X 1/4" P/T	61.00
HME42	Oiler #2, 2" dia. X 3/8" P/T	63.50
HME43	Oiler #3, 2 1/4" dia. X 3/8" P/T	69.50
HME44	Oiler #4, 2 1/2" dia. X 3/8" P/T	74.00
HME 45	Oiler #5, 3" dia. X 1/2" P/T	81.00

**OILER GLASS**

HME46	Oiler Glass #000, 1" OD X 7/8"	5.50
HME47	Oiler Glass #00, 1 1/8" OD X 1"	6.50
HME48	Oiler Glass #0, 1 1/4" OD X 1 1/8"	6.50
HME49	Oiler Glass #1, 1 1/2" OD X 1 3/8"	7.50
HME50	Oiler Glass #1 1/2, 1 3/4" OD X 1 5/8"	8.00
HME51	Oiler Glass #2, 2" OD X 1 7/8"	8.50
HME52	Oiler Glass #3, 2 1/4" OD X 2 1/8"	12.50
HME53	Oiler Glass #4, 2 1/2" OD X 2 3/8"	16.50
HME54	Oiler Glass #5, 3" OD X 3"	18.50
HME55	Oiler Glass #6, 3 1/2" OD X 4"	28.00

**OILER GLASS GASKETS**

HME58	Gasket, #000, 1" OD	.50
HME59	Gasket, #00, 1 1/8" OD	.50
HME60	Gasket, #0, 1 1/4" OD	.55
HME61	Gasket, #1, 1 1/2" OD	.60
HME61A	Gasket, #1 1/2, 1 3/4" OD	.75

HME62	Gasket, #2, 2" OD	.75
HME63	Gasket, #3, 2 1/4" OD	.85
HME64	Gasket, #4, 2 1/2" OD	.90

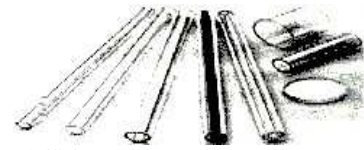

HME65	Gasket, #5, 3" OD	1.00
HME66	Gasket, #6, 3 1/2" OD	1.25

**OILER SIGHT GLASS**

HME67	Oiler Sight Glass, 1/2" dia. X 1 1/2"	2.00
HME68	Oiler Sight Glass, 1/2" dia. X 5/8"	2.00
HME69	Oiler Sight Glass, 1/2" dia. X 3/4"	2.00
HME70	Oiler Sight Glass, 1/2" dia. X 7/8"	2.00
HME71	Oiler Sight Glass, 1/2" dia. X 1"	2.00
HME72	Oiler Sight Glass, 5/8" dia. X 5/8"	2.00
HME73	Oiler Sight Glass, 5/8" dia. X 3/4"	2.00
HME74	Oiler Sight Glass, 5/8" dia. X 7/8"	2.00
HME75	Oiler Sight Glass, 5/8" dia. X 1"	2.00
HME76	Oiler Sight Glass, 3/4" dia. X 5/8"	2.00
HME77	Oiler Sight Glass, 3/4" dia. X 3/4"	2.00
HME78	Oiler Sight Glass, 3/4" dia. X 7/8"	2.00
HME79	Oiler Sight Glass, 3/4" dia. X 1"	2.00
HME80	Oiler Sight Glass, 7/8" dia. X 5/8"	2.00
HME81	Oiler Sight Glass, 7/8" dia. X 3/4"	2.00
HME82	Oiler Sight Glass, 7/8" dia. X 7/8"	2.00
HME83	Oiler Sight Glass, 7/8" dia. X 1"	2.00

Any length sight glass available-standard diameters to 7/8"

HME84	Oiler Sight Glass Gasket (Pair), 1/2" dia.	.50
HME85	Oiler Sight Glass Gasket (Pair), 5/8" dia.	.50
HME86	Oiler Sight Glass Gasket (Pair), 3/4" dia.	.50
HME87	Oiler Sight Glass Gasket (Pair), 7/8" dia.	.50

**OILER FILL CAPS**

HME88	Oiler Fill Cap & Retainer 5/16" X 24 TPI	6.50
HME89	Oiler Fill Cap & Retainer 3/8" X 24 TPI	7.00
HME90	Oiler Fill Cap & Retainer 7/16" X 20 TPI	7.50
HME91	Oiler Fill Cap & Retainer 9/16" X 20 TPI	8.00

**OIL CUPS (Brass with screw on lid)**

HME391	Oil Cup, #0, 3/4" dia. X 1/8" NPT	22.00
HME392	Oil Cup, #1, 7/8" dia. X 1/8" NPT	24.00

**PRIMING CUPS**

HME92	Priming Cup, Cast Machined Brass 1/8"	22.50
HME93	Priming Cup, Cast Machined Brass 1/4"	22.50

**CHECKBALLS**

P251	Stainless Steel Checkball, 1/8"	.50
P252	Stainless Steel Checkball, 5/32"	.50
P253	Stainless Steel Checkball, 3/16"	.50
P254	Stainless Steel Checkball, 7/32"	.50
P255	Stainless Steel Checkball, 1/4"	.50
P256	Stainless Steel Checkball, 9/32"	.50
P257	Stainless Steel Checkball, 5/16"	.50
P258	Stainless Steel Checkball, 3/8"	.65
P259	Stainless Steel Checkball, 7/16"	.75

**J-B WELD & KROIL**

JB01	J-B Weld, 1 oz.	6.50
JB05	J-B Weld, 5oz.	17.50
"Cast iron repair the simple way"		
KR01	Kroil Penetrating Fluid, 8 oz.	8.00
KR06	Kroil Penetrating Fluid, Aerosol Can, 10oz.	13.50



## BELTING SUPPLIES

Flat

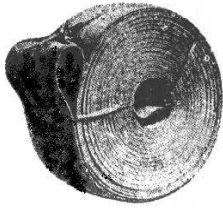

3 PLY		
Part#	Width	Price/foot
B31	1"	2.00
B31A	1 1/4"	2.25
B31B	1 1/2"	2.50
B31C	1 3/4"	2.75
B32	2"	3.00
B33	3"	3.75
B34	4"	4.00
B35	5"	4.50
B36	6"	5.25

4 PLY		
Part#	Width	Price/foot
Not sold in 1 inch		
B42	2"	3.50
B43	3"	4.75
B44	4"	5.50
B45	5"	6.25
B46	6"	7.50

(Flat belting is canvas rubberized belting like the belting used in the teens and 20's. Three ply is usually substantial for most line shafts and belt driven equipment using engines up to 20HP). Narrow three ply belts are good for shop machinery, fans, etc.

\*\*3 ply belting is sold in any width starting at 1/2".

## Round Leather

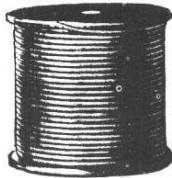

RL101	1/8"	2.25 per ft.
RL102	3/16"	2.25 per ft.
RL103	1/4"	2.50 per ft.
RL104	3/8"	3.50 per ft.
RL200	Belt Hook (normal use-one per belt)	.85 ea.

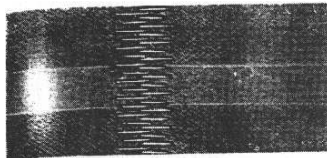

## Clipper Belt Fasteners

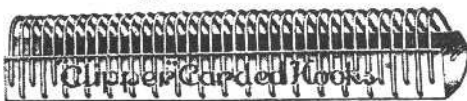

## Lacing, Clipper Style

You need a Clipper Lacer to install this lacing - we can do it for you too.

Part #	Belt Thickness	Length	Price
CL-25LP	1/16"-1/8"	6"	3.00
CL-1	1/8"-5/32"	6"	3.00
CL-2	5/32"-3/16"	12"	3.50
CL-3	3/16"-7/32"	12"	3.50
CL-4	7/32"-1/4"	12"	3.50
CL-5	9/32"-5/16"	12"	4.00
CL-6	5/16"-3/8"	12"	4.00

*We can supply all your belting needs. Just tell us what width and length you need and if you want lacing installed. We carry a number of sizes and thickness as well as round belting, and if we don't show the size you need just give us a call and we'll get you fixed up as we have many sizes available that we don't list. Installation of Clipper Lacing in your belt is only \$10 and when it gets to you it's ready to use!*

## Lacing, Alligator Style - all 12" length pieces

No special tool required.



ALLIGATOR

Part #	Belt Thickness	Price
AL-7	3/32"-9/64"	3.00
AL-15	1/8"-5/32"	3.50
AL-20	5/32"-3/16"	4.00
AL-25	3/16"-7/32"	4.00
AL-27	1/4"-9/32"	4.00
AL-35	9/32"-5/16"	6.00
AL-45	5/16"-3/8"	6.00

## Need Endless Belt?

Call for Quote

Lacing Pins 12" \$1.50 ea.

# BRASS PIPE AND FITTINGS

## COMPRESSION FITTINGS

Dimensions are  
Tube O.D. x Pipe Size

### MALE CONNECTOR



Part #		Price
CB68A	1/8 X 1/8	1.50
CB68B	3/16X 1/8	1.50
CB68BB	3/16X 1/4	2.55
CB68C	1/4 X 1/8	1.50
CB68CC	1/4 X 1/4	1.80
CB68CE	1/4 X 3/8	2.50
CB68CF	1/4 X 1/2	3.50
CB68E	3/8 X 1/8	1.75
CB68EE	3/8 X 1/4	1.75
CB68EEE	3/8 X 3/8	2.50
CB68EF	3/8 X 1/2	3.35

### FEMALE CONNECTOR



Part #		Price
CB66A	1/8 X 1/8	1.90
CB66B	3/16 X1/8	2.10
CB66BB	3/16 X1/4	4.25
CB66C	1/4 X 1/8	1.55
CB66CC	1/4 X 1/4	2.50
CB66CE	1/4 X 3/8	3.75
CB66CF	1/4 X 1/2	5.50
CB66E	3/8 X 1/8	2.25
CB66EE	3/8 X 1/4	3.00
CB66EEE	3/8 X 3/8	3.50
CB66EF	3/8 X 1/2	5.00

### UNION



Part #	Tube O.D.	Price
CB62A	1/8	2.50
CB62B	3/16	2.50
CB62C	1/4	2.50
CB62E	3/8	2.75

### MALE ELBOW



Part #		Price
CB69A	1/8 X 1/8	2.50
CB69B	3/16 X1/8	3.00
CB69BB	3/16 X1/4	5.25
CB69C	1/4 X 1/8	2.25
CB69CC	1/4 X 1/4	2.50
CB69CE	1/4 X 3/8	4.25
CB69E	3/8 X 1/8	3.25
CB69EE	3/8 X 1/4	3.00
CB69EEE	3/8 X 3/8	3.75
CB69EF	3/8 X 1/2	4.00

## FLARED FITTINGS

Dimensions are  
Tube O.D. x Pipe Size

### MALE CONNECTOR



Part #		Price
CB48A	1/8 X 1/8	3.25
CB48B	3/16X1/8	1.50
CB48C	1/4 X 1/8	1.75
CB48CC	1/4 X 1/4	2.00
CB48CE	1/4 X 3/8	2.40
CB48CF	1/4 X 1/2	3.25
CB48E	3/8 X 1/8	2.40
CB48EE	3/8 X 1/4	2.00
CB48EEE	3/8 X 3/8	2.75
CB48EF	3/8 X 1/2	3.25
CB48EJ	3/8 X 3/4	4.25
CB48F	1/2 X 3/8	2.75
CB48FC	1/2 X 1/4	3.00
CB48FF	1/2 X 1/2	3.25
CB48FH	1/2 X 3/4	4.00

### FEMALE CONNECTOR



Part #		Price
CB46A	1/8 X 1/8	3.90
CB46B	3/16X1/8	2.70
CB46C	1/4 X 1/8	1.50
CB46CC	1/4 X 1/4	2.10
CB46CE	1/4 X 3/8	2.70
CB46CF	1/4 X 1/2	3.20
CB46E	3/8 X 1/8	2.40
CB46EE	3/8 X 1/4	2.40
CB46EEE	3/8 X 3/8	2.70
CB46EF	3/8 X 1/2	3.20
CB46EJ	3/8 X 3/4	3.90
CB46F	1/2 X 3/8	2.70
CB46FC	1/2 X 1/4	3.00
CB46FF	1/2 X 1/2	3.30
CB46FJ	1/2 X 3/4	4.25

### SHORT NUT



Part #		Price
CB41A	1/8	1.80
CB41B	3/16	1.50
CB41C	1/4	1.50
CB41E	3/8	1.65
CB41F	1/2	2.25

## WE'RE BUYING!

Engines and parts, belt driven equipment such as small mills (under 500 lbs), grinders, saws, related misc. found in old outbuildings or shops. One piece or entire collections including all the old misc. pieces that find their way into a collection. Yes we'll trade engines and/or parts for items we're interested in. Besides gas engines & parts we also buy steam related items, brass whistles, oilers, etc. Can't cover all our interests here. What ya got?

## FLARED FITTINGS

### LONG NUT



Part #		Price
CB141A	1/8	2.90
CB141B	3/16	2.10
CB141C	1/4	2.10
CB141E	3/8	2.50
CB141F	1/2	3.30

### UNION



Part #		Price
CB42A	1/8	3.50
CB42B	3/16	2.90
CB42C	1/4	1.50
CB42E	3/8	2.10
CB42F	1/2	2.80

### MALE ELBOW



Part #		Price
CB49A	1/8 X 1/8	4.20
CB49B	3/16X1/8	3.15
CB49BB	3/16X1/4	3.90
CB49C	1/4 X 1/8	2.40
CB49CC	1/4 X 1/4	3.00
CB49CE	1/4 X 3/8	3.90
CB49CF	1/4 X 1/2	4.50
CB49E	3/8 X 1/8	3.30
CB49EE	3/8 X 1/4	3.20
CB49EEE	3/8 X 3/8	3.30
CB49EF	3/8 X 1/2	3.90
CB49EJ	3/8 X 3/4	6.90
CB49F	1/2 X 3/8	4.10
CB49FC	1/2 X 1/4	4.10
CB49FF	1/2 X 1/2	4.50
CB49FJ	1/2 X 3/4	7.50

## NIPPLES

Part #		Price
TRB5501	1/8 Close	1.20
TRB5503	1/8 X 1.5	1.80
TRB5505	1/8 X 2	2.10
TRB5507	1/8 X 2.5	2.40
TRB5509	1/8 X 3	2.70
TRB5511	1/8 X 3.5	2.70
TRB5513	1/8 X 4	2.70
TRB5515	1/8 X 4.5	3.00
TRB5517	1/8 X 5	3.00
TRB5519	1/8 X 5.5	3.30
TRB5521	1/8 X 6	3.60

## NIPPLES cont.

TRB5535	1/4 Close	1.80
TRB5537	1/4 X 1.5	1.80
TRB5539	1/4 X 2	2.10
TRB5541	1/4 X 2.5	2.70
TRB5543	1/4 X 3	3.00
TRB5545	1/4 X 3.5	3.00
TRB5547	1/4 X 4	3.60
TRB5549	1/4 X 4.5	3.90
TRB5551	1/4 X 5	4.20
TRB5553	1/4 X 5.5	4.20
TRB5555	1/4 X 6	4.80
TRB5569	3/8 Close	1.80
TRB5571	3/8 X 1.5	2.10
TRB5573	3/8 X 2	2.70
TRB5575	3/8 X 2.5	2.70
TRB5577	3/8 X 3	3.30
TRB5579	3/8 X 3.5	3.60
TRB5581	3/8 X 4	4.20
TRB5583	3/8 X 4.5	4.50
TRB5585	3/8 X 5	4.80
TRB5587	3/8 X 5.5	5.10
TRB5589	3/8 X 6	5.70
TRB5603	1/2 Close	2.10
TRB5605	1/2 X 1.5	2.50
TRB5607	1/2 X 2	3.00
TRB5609	1/2 X 2.5	3.60
TRB5611	1/2 X 3	4.20
TRB5613	1/2 X 3.5	4.50
TRB5615	1/2 X 4	5.10
TRB5617	1/2 X 4.5	5.60
TRB5619	1/2 X 5	5.95
TRB5621	1/2 X 5.5	6.30

## MORE NIPPLES ON THE NEXT PAGE

Welcome to our hardware section! We list five full pages of hardware we feel will be used by steam and gas engine collector's for their engines, boilers, pumps, and etc. Many of these items are no longer readily available at most hardware stores. Need heavy hex nuts? Jam nuts? Studs? 6" of brass bar stock? Shim stock? Fuel line? You'll find it here.

# Brass Pipe And Fittings cont.

## BRASS NIPPLES (cont.)



Part #		Price
TRB5623	1/2 X 6	6.90
TRB5637	3/4 X Close	3.00
TRB5638	3/4 X 1.5	3.30
TRB5639	3/4 X 2	3.90
TRB5641	3/4 X 2.5	4.80
TRB5643	3/4 X 3	5.40
TRB5645	3/4 X 3.5	5.40
TRB5647	3/4 X 4	6.30
TRB5649	3/4 X 4.5	6.60
TRB5651	3/4 X 5	7.20
TRB5653	3/4 X 5.5	8.10
TRB5655	3/4 X 6	9.60
TRB5669	1 X Close	4.20
TRB5671	1 X 2	5.10
TRB5673	1 X 2.5	6.00
TRB5675	1 X 3	6.60
TRB5677	1 X 3.5	7.45
TRB5679	1 X 4	7.45
TRB5681	1 X 4.5	9.00
TRB5683	1 X 5	9.90
TRB5685	1 X 5.5	10.50
TRB5687	1 X 6	12.00

## 90 DEGREE ELBOW



Part #		Price
CB1AF	1/8	2.70
CB1CF	1/4	3.00
CB1EF	3/8	3.00
CB1F	1/2	3.60
CB1JC	3/4	5.10
CB1NC	1	7.50

## TEE



Part #		Price
CB01AF	1/8	3.60
CB01CF	1/4	3.60
CB01EF	3/8	3.90
CB01FF	1/2	4.20
CB01J	3/4	5.70
CB01N1	1	10.50

## UNION



Part #		Price
CB104A	1/8	8.40
CB104C	1/4	8.40
CB104E	3/8	8.40
CB104F	1/2	9.30
CB104J	3/4	12.60
CB104N	1	15.00

## COUPLING



Part #		Price
CB103A	1/8	2.40
CB103C	1/4	2.40
CB103E	3/8	3.00
CB103F	1/2	3.60
CB103J	3/4	4.80

## COUPLING (cast)

Part #		Price
TB3513	3/8	2.40
TB3515	1/2	3.30
TB3517	3/4	4.80
TB3519	1	7.20
TB3521	1 1/4	11.40
TB3523	1 1/2	15.00

## HEX BUSHING



Part #	male X female	Price
CB0C	1/4 X 1/8	1.20
CB0E	3/8 X 1/8	1.50
CB0EE	3/8 X 1/4	1.50
CB0FA	1/2 X 1/8	2.00
CB0FC	1/2 X 1/4	2.00
CB0F	1/2 X 3/8	2.00
CB0JA	3/4 X 1/8	3.20
CB0JC	3/4 X 1/4	3.20
CB0JE	3/4 X 3/8	3.20
CB0J	3/4 X 1/2	3.20
CB0NC	1 X 1/4	4.75
CB0NE	1 X 3/8	4.95
CB0NF	1 X 1/2	5.10
CB0NJ	1 X 3/4	5.10

## FACE BUSHING



Part #	male X female	Price
CBFB0E	3/8 X 1/8	2.70
CBFB0EE	3/8 X 1/4	3.30
CBFB0F	1/2 X 3/8	3.30
CBFB0J	3/4 X 1/2	3.60

## REDUCING COUPLING



Part #	male X female	Price
CB9C	1/4 X 1/8	2.10
CB9E	3/8 X 1/8	3.00
CB9EE	3/8 X 1/4	3.00
CB9FA	1/2 X 1/8	4.20
CB9FC	1/2 X 1/4	4.20
CB9F	1/2 X 3/8	4.20
CB9JC	3/4 X 1/4	5.40
CB9JE	3/4 X 3/8	5.40
CB9J	3/4 X 1/2	5.40
CB9NJ	1 X 3/4	7.80

## MALE - MALE HEX NIPPLE



Part #	size X length	Price
CB2XA	1/8 X .97	1.50
CB2XC	1/4 X 1.12	1.50
CB2XE	3/8 X 1.31	2.10
CB2XF	1/2 X 1.50	3.00
CB2XJ	3/4 X 1.56	4.80
CB2XN	1 X 2.315	9.30

## MALE-MALE HEX NIPPLE REDUCING



Part #	size X size	Price
CB2RCA	1/4 X 1/8	1.50
CB2REA	3/8 X 1/8	2.70
CB2REC	3/8 X 1/4	2.70
CB2RFC	1/2 X 1/4	3.60
CB2RFE	1/2 X 3/8	3.60
CB2RJF	3/4 X 1/2	5.40

## PLUG-SQUARE HEAD



Part #		Price
CB09A	1/8	.90
CB09C	1/4	1.20
CB09E	3/8	1.80
CB09F	1/2	2.70
CB09J	3/4	3.60
CB09N	1	4.80

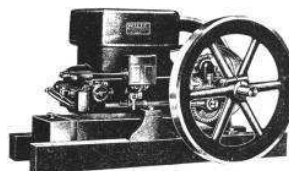

## PLUG-HEX HEAD



Part #		Price
CB09XA	1/8	1.50
CB09XC	1/4	1.80
CB09XE	3/8	1.80
CB09XF	1/2	2.40
CB09XJ	3/4	3.60
CB09XN	1	6.60

## PLUG-SLOTTED



Part #		Price
CB09WA	1/8	1.20
CB09WC	1/4	1.50
CB09WE	3/8	1.80

## PIPE CAP



Part #		Price
CB8A	1/8	1.50
CB8C	1/4	1.50
CB8E	3/8	2.10
CB8F	1/2	3.00
CB8J	3/4	4.20
CB8N	1	7.20

## PIPE CAP (cast)



Part #		Price
TB4004	3/8	2.40
TB4006	1/2	3.00
TB4008	3/4	4.20
TB4012	1	5.10
TB4014	1 1/4	9.00
TB4016	1 1/2	12.00
TB4018	2	21.00

## RED BRASS PIPE

Min. order, 1ft., max. length 3ft  
Plain Ends



Part #		Price/foot
TRB7948	1/8	5.40
TRB7950	1/4	7.20
TRB7951	3/8	8.10
TRB7952	1/2	11.70
TRB7953	3/4	14.95
TRB7954	1	19.05

# Steel Pipe and Fittings

## STEEL NIPPLES



Part #	Size X Length	Price
TS01	1/8 Close	1.20
TS03	1/8 X 1.5	1.20
TS05	1/8 X 2	1.20
TS07	1/8 X 2.5	1.50
TS09	1/8 X 3	1.50
TS11	1/8 X 3.5	1.80
TS13	1/8 X 4	2.10
TS15	1/8 X 4.5	3.00
TS17	1/8 X 5	3.00
TS19	1/8 X 5.5	3.30
TS21	1/8 X 6	3.30
TS59	1/4 Close	1.20
TS61	1/4 X 1.5	1.20
TS63	1/4 X 2	1.20
TS65	1/4 X 2.5	1.50
TS67	1/4 X 3	1.50
TS69	1/4 X 3.5	1.80
TS71	1/4 X 4	2.10
TS73	1/4 X 4.5	2.70
TS75	1/4 X 5	2.70
TS77	1/4 X 5.5	3.30
TS79	1/4 X 6	3.30
TS117	3/8 Close	1.20
TS119	3/8 X 1.5	1.50
TS121	3/8 X 2	1.50
TS123	3/8 X 2.5	1.50
TS125	3/8 X 3	1.80
TS127	3/8 X 3.5	2.10
TS129	3/8 X 4	2.10
TS131	3/8 X 4.5	3.00
TS133	3/8 X 5	3.00
TS135	3/8 X 5.5	3.30
TS137	3/8 X 6	3.30
TS175	1/2 Close	1.20
TS177	1/2 X 1.5	1.50
TS179	1/2 X 2	1.50
TS181	1/2 X 2.5	1.80
TS183	1/2 X 3	1.80
TS185	1/2 X 3.5	1.80
TS187	1/2 X 4	2.10
TS189	1/2 X 4.5	2.10
TS109	1/2 X 5	2.70
TS1093	1/2 X 5.5	2.70
TS1095	1/2 X 6	3.00
TS233	3/4 Close	1.50
TS235	3/4 X 1.5	1.50
TS237	3/4 X 2	1.50
TS239	3/4 X 2.5	1.50
TS241	3/4 X 3	1.80
TS243	3/4 X 3.5	1.80
TS245	3/4 X 4	2.10
TS247	3/4 X 4.5	2.40
TS249	3/4 X 5	2.70
TS251	3/4 X 5.5	3.30
TS253	3/4 X 6	3.30
TS291	1 Close	1.80
TS293	1 X 2	1.80
TS295	1 X 2.5	2.10
TS297	1 X 3	2.10
TS298	1 X 3.5	2.40
TS301	1 X 4	2.40
TS303	1 X 4.5	2.70
TS305	1 X 5	3.00
TS307	1 X 5.5	3.30

## NIPPLES cont.

Part #	Size	Price
TS309	1 X 6	3.60
TS347	1 1/4 Close	2.40
TS349	1 1/4 X 2	2.40
TS351	1 1/4 X 2.5	3.00
TS353	1 1/4 X 3	3.60
TS403	1 1/2 Close	2.70
TS405	1 1/2 X 2	3.60
TS407	1 1/2 X 2.5	4.20
TS409	1 1/2 X 3	4.80
TS459	2 Close	3.60
TS463	2 X 3	4.80
TS513	2 1/2 Close	10.80
TS515	2 1/2 X 3	12.60

Pipe nipples avail. up to 12" length

## COUPLINGS



Part #	Size	Price
TCS225	1/8	1.50
TCS235	1/4	2.10
TCS245	3/8	2.40
TCS275	1/2	2.70
TCS285	3/4	3.60
TCS295	1	4.80
TCS325	1 1/4	6.00
TCS335	1 1/2	7.50
TCS345	2	10.80

## ELBOWS



Part #	Size	Price
TE01	1/8	2.10
TE02	1/4	2.10
TE03	3/8	2.10
TE04	1/2	2.10
TE05	3/4	2.40
TE06	1	3.30
TE07	1 1/4	5.10
TE08	1 1/2	7.20
TE09	2	11.40

## HEX BUSHINGS



Part #	Size	Price
TH80	1/4 X 1/8	.90
TH81	3/8 X 1/8	.90
TH82	3/8 X 1/4	.90
TH83	1/2 X 1/8	1.50
TH84	1/2 X 1/4	1.50
TH85	1/2 X 3/8	1.50
TH86	3/4 X 1/8	2.10
TH87	3/4 X 1/4	2.10
TH88	3/4 X 3/8	2.10
TH89	3/4 X 1/2	2.10
TH90	1 X 1/8	3.60
TH91	1 X 1/4	3.60
TH92	1 X 3/8	3.90
TH93	1 X 1/2	3.90
TH94	1 X 3/4	3.90
TH95	1 1/4 X 1	4.20
TH96	1 1/2 X 1 1/4	4.20
TH97	2 X 1 1/2	5.40
TH98	2 1/2 X 2	7.20

## REDUCER COUPLINGS



Part #	Size	Price
TRC50	1/4 X 1/8	2.40
TRC51	3/8 X 1/8	3.60
TRC52	3/8 X 1/4	2.40
TRC53	1/2 X 1/8	2.70
TRC54	1/2 X 1/4	2.40
TRC55	1/2 X 3/8	2.40
TRC56	3/4 X 1/8	3.30
TRC57	3/4 X 1/4	3.30
TRC58	3/4 X 3/8	3.30
TRC59	3/4 X 1/2	3.30
TRC60	1 X 1/4	5.70
TRC61	1 X 3/8	5.10
TRC62	1 X 1/2	4.20
TRC63	1 X 3/4	4.20
TRC64	1 1/4 X 1/2	5.70
TRC65	1 1/4 X 3/4	5.40
TRC66	1 1/4 X 1	5.40
TRC67	1 1/2 X 3/4	8.40
TRC68	1 1/2 X 1	7.50
TRC69	1 1/2 X 1 1/4	7.20
TRC70	2 X 1 1/4	10.80
TRC71	2 X 1 1/2	10.80

## TEES



Part #	Size	Price
TT226	1/8	2.40
TT227	1/4	2.40
TT228	3/8	2.40
TT229	1/2	2.40
TT230	3/4	2.40
TT231	1	3.60
TT232	1 1/4	6.00
TT233	1 1/2	7.20
TT234	2	12.00

## STREET ELBOWS 90°



Part #	Size	Price
TSE118	1/8	3.00
TSE119	1/4	3.00
TSE120	3/8	3.00
TSE121	1/2	3.30
TSE122	3/4	3.30
TSE123	1	4.20
TSE124	1 1/4	6.00
TSE125	1 1/2	8.10
TSE126	2	13.20
TSE127	2 1/2	28.80

## STEEL UNIONS



Part #	Size	Price
TU835	1/8	10.20
TU836	1/4	10.20
TU837	3/8	7.20
TU838	1/2	7.20
TU839	3/4	7.80
TU840	1	9.60

## STEEL UNIONS cont.

TU841	1 1/4	13.20
TU842	1 1/2	16.80
TU843	2	19.20

## STEEL CAPS

S=steel, M=malleable iron



Part #	Size	Price
TSC225	1/8S	.90
TSC235	1/4S	.90
TSC245	3/8S	1.20
TSC699	1/2M	1.80
TSC700	3/4M	1.80
TSC701	1M	2.40
TSC702	1 1/4M	3.30
TSC703	1 1/2M	3.90
TSC704	2M	6.00
TSC705	2 1/2M	9.00

## STEEL SQUARE HEAD PLUGS



Part #	Size	Price
THP525	1/8	.30
THP535	1/4	.45
THP545	3/8	.55
THP555	1/2	.70
THP565	3/4	.90
THP575	1	1.80
THP585	1 1/4	3.00
THP595	1 1/2	5.40
THP600	2	6.00
THP605	2 1/2	11.40

## SQUARE SOCKET PLUGS



Part #	Size	Price
TSP696	1/8	.35
TSP698	1/4	.45
TSP700	3/8	.45
TSP702	1/2	.55
TSP704	3/4	1.80
TSP706	1	3.90
TSP708	1 1/4	4.80
TSP710	1 1/2	6.30
TSP712	2	11.40
TSP714	2 1/2	15.00

## BLACK PIPE

Max. shipping length 3 ft.



Part #	Size	\$/foot
TBP05	1/8	3.00
TBP06	1/4	3.30
TBP07	3/8	3.45
TBP08	1/2	3.90
TBP09	3/4	4.20
TBP10	1	5.40
TBP11	1 1/4	6.30
TBP12	1 1/2	8.40

# MISCELLANEOUS SUPPLIES

## BAR STOCK

This section for bar stock is for those of you who do small jobs. Prices are for 6" length unless otherwise noted. Max. length 3 ft .

\*\* Indicates price for 1 ft length

## ALUMINUM

Heat treatable, machinable, weldable, corrosion resistant.

### ROUNDS

Part#	Size	Price
HD120	1/4"	\$2.20**
HD1205	5/16"	2.50**
HD121	3/8"	2.75**
HD122	1/2"	2.75
HD123	3/4"	3.30
HD1235	7/8"	3.85
HD124	1"	4.40

### HEXAGON

Part#	Size	Price
HD130	1/4"	2.75**
HD132	3/8"	2.75
HD133	1/2"	3.60
HD135	5/8"	4.95
HD136	3/4"	6.60
HD138	7/8"	8.00
HD139	1"	8.80

### SQUARES

HD140	1/4"	1.95**
HD141	3/8"	2.50**
HD142	1/2"	2.50
HD143	5/8"	3.05
HD144	3/4"	4.95
HD145	7/8"	5.25
HD146	1"	7.45

## BRASS

Free machining, minimum tool wear.

### Rounds

HD150	1/8"	1.40**
HD151	3/16"	1.95**
HD152	1/4"	1.65
HD153	5/16"	2.20
HD154	3/8"	2.75
HD155	7/16"	3.60
HD156	1/2"	4.15
HD157	9/16"	4.70
HD158	5/8"	6.05
HD159	3/4"	7.70
HD160	7/8"	9.35
HD161	1"	11.30
HD162	1 1/8"	14.05
HD163	1 1/4"	16.80

## HEXAGON (Brass)

Part#	Size	Price
HD170	3/16"	2.20**
HD171	1/4"	2.75**
HD172	5/16"	2.75
HD173	3/8"	3.60
HD174	7/16"	3.85
HD175	1/2"	4.70
HD176	9/16"	5.80
HD177	5/8"	7.05
HD178	3/4"	9.80
HD179	7/8"	12.10
HD180	1"	15.40

## SQUARE (Brass)

Part#	Size	Price
HD190	1/8"	1.65**
HD191	3/16"	3.05**
HD192	1/4"	2.20
HD193	5/16"	2.50
HD194	3/8"	3.60
HD195	7/16"	4.70
HD196	1/2"	5.50
HD197	9/16"	6.60
HD198	5/8"	7.70
HD199	3/4"	10.45
HD200	1"	18.15

## GASKET MATERIAL

P12 - Gasket material for heads and ignitors. 1/16" thick.  
11 1/2" X 11 1/2" piece - \$9.00  
P130 - Cork gasket material, oil resistant, 1/16" thick.  
12" X 12" piece - \$4.00

## BRASS COTTER KEYS

	Diam.	Lgth.	Price
HD263	1/16"	1/2"	.40
HD2631	1/16"	3/4"	.40
HD2633	3/32	1/2"	.40
HD2634	3/32"	3/4"	.40
HD2635	3/32"	1"	.40
HD2636	1/8"	3/4"	.40
HD2637	1/8"	1"	.40
HD2639	5/32"	1 1/2"	.77
HD2640	5/32"	2"	.85
HD2641	3/16"	1 1/2"	1.00

## Fuel Line Tubing and Hose

Priced per foot.			
Y=yellow brass C=copper			
1/8"	HD270	Y	3.60
	HD280	C	1.75
3/16"	HD271	Y	3.60
	HD281	C	1.75
1/4"	HD272	Y	3.85
	HD282	C	2.25
5/16"	HD273	Y	3.85
	HD283	C	2.75
3/8"	HD274	Y	5.45
	HD284	C	3.25

## OIL HARDENING GROUND

### DRILL ROD

(Price for 6" length)  
Tolerance +/- 0.0005"

Part#	Size	Price
HD210	1/16"	1.65
HD211	1/8"	1.65
HD212	3/16"	1.65
HD213	1/4"	1.65
HD214	5/16"	1.65
HD215	3/8"	1.95
HD216	7/16"	2.50
HD217	1/2"	2.75
HD218	9/16"	3.30
HD219	5/8"	3.30
HD220	11/16"	4.15
HD221	3/4"	4.40
HD222	13/16"	5.80
HD223	7/8"	6.35
HD224	15/16"	7.45
HD225	1"	8.25
HD226	1 1/16"	9.10
HD227	1 1/8"	9.90
HD228	1 3/16"	11.55
HD229	1 1/4"	12.10
HD230	1 5/16"	13.75
HD231	1 3/8"	14.05

## Hose Barb Fittings

Brass. Intended for use with hose clamps. M=male, F=female, S=splice

Part#	Type	I.D.	NPT	Price
HD2961	M	3/16	1/8	2.10
HD2971	F	3/16	1/8	2.40
HD2982	S	3/16		2.40
HD2962	M	3/16	1/4	2.40
HD2972	F	3/16	1/4	4.20
HD2983	S	1/4		2.10
HD2963	M	1/4	1/8	1.80
HD2973	F	1/4	1/8	2.40
HD2984	S	5/16		2.40
HD2964	M	1/4	1/4	1.80
HD2974	F	1/4	1/4	3.00
HD2985	S	3/8		2.70
HD2965	M	1/4	3/8	3.00
HD2975	F	1/4	3/8	2.70
HD2966	M	5/16	1/8	2.10
HD2976	F	5/16	1/8	2.70
HD29665	M	5/16	1/4	2.10
HD2977	F	5/16	1/4	2.70
HD2967	M	5/16	3/8	3.60
HD2978	F	5/16	3/8	4.20
HD2968	M	3/8	1/8	2.10
HD2979	F	3/8	1/8	2.70
HD2969	M	3/8	1/4	2.40
HD2980	F	3/8	1/4	2.40
HD2970	M	3/8	3/8	3.00
HD2981	F	3/8	3/8	3.00

## Hose Push-On Fittings

Brass, no clamps required.

Part#	Type	I.D.	NPT	Price
HD3001	M	1/4	1/8	2.40
HD3010	F	1/4	1/8	4.20
HD3020	S	1/4		2.70
HD3002	M	1/4	1/4	2.40
HD3011	F	1/4	1/4	3.60
HD3021	S	5/16		3.00
HD3003	M	1/4	3/8	3.60
HD3012	F	1/4	3/8	4.20

## Hose Push-On Fittings (cont.)

HD3022	S	3/8		3.60
HD3004	M	5/16	1/8	3.00
HD3005	M	5/16	1/4	3.00
HD3014	F	3/8	1/4	3.60
HD3006	M	3/8	1/8	3.30
HD3015	F	3/8	3/8	3.60
HD3007	M	3/8	1/4	2.70
HD3008	M	3/8	3/8	3.60

## Fuel Line Check Valves

HM0285 1/4" NPT to 1/4" NPT \$30.00  
Assoc. style, ball, horizontal use  
HM3405 1/8" NPT - 1/4" NPT \$15.75  
Hercules style, vertical use, in-line  
HM855 1/8" NPT \$14.00  
Screen in bottom, in-tank, vertical use

**NAMEPLATE FASTENERS**  
Stainless steel drive screws, smooth round head. Priced per pair.



Part#	Hole Size	Drill Size	Length	Price
HD360	.104	#37	3/16"	.65
HD361	.104	#37	1/4"	.65
HD362	.120	#31	1/4"	.65
HD363	.120	#31	5/16"	.65
HD365	.144	#27	1/4"	.65
HD366	.144	#27	3/8"	.65
HD367	.191	#11	1/2"	.90

## We're Buying!

Old Gas Engines  
Related Accessories & Parts  
Old Belt Driven Equipment  
Inst. & Parts Manuals  
Oilers  
Steam Engines & Misc. Items  
Steam Whistles  
Unusual Sparkplugs  
One Cyl. Gas Engine Mags  
Old Signs & Sale's Brochures  
Complete Collections  
Model Engines  
Etc., Etc., Etc.

Prefer within 300 miles but will consider longer distance if a good load.

## "YE OLD COMPUTER"

Don't make a face. You don't have too have brain 1 to use one (I know-I have two in my office and one at home). This is a very important and helpful tool to many of us old iron collector's. Did ya know you can go to hitnmiss.com and see our complete catalog, pictures of used parts and engines for sale, pictures of our shop and grounds, our gang, video of our 2010 swap and more. Also keep close contacts with other collector's with email and chat rooms. Ton's of info on gas engines on web sites, ebay, etc. (many links from our site), and so much more. You'll only cuss a little bit.

# MISCELLANEOUS SUPPLIES

## NUTS & STUDS

### Nut, Thumb (Brass), Round Knurled

HD372	8-32	.75ea.	HD375	12-24	1.00 ea.
HD373	10-24	1.00 ea.	HD376	1/4"-20	1.25 ea.
HD374	10-32	1.00 ea.	HD377	5/16"-18	1.50 ea.



### Nut, Special Shape Wing Nuts (made from malleable iron)



Type	Thread	A	B	C	Price
HD380	#1 8-32	1"	7/16"	1/4"	3.50
HD381	#1 10-24	1 1/8"	1/2"	3/8"	2.50
HD382	#2 1/4"-20	1 1/8"	5/8"	7/16"	2.75
HD383	#2 5/16"-18	1 1/4"	21/32"	15/36"	3.00
HD384	#2 3/8"-16	1 1/2"	3/4"	9/16"	3.00
HD385	#3 1/4"-20	1 7/8"	1 3/8"	11/16"	3.50
HD386	#3 5/16"-18	1 7/8"	1 3/8"	11/16"	4.00
HD397	#3 3/8"-16	1 7/8"	1 3/8"	11/16"	4.00

### Castle Nuts-N.F. Threads, Price each

HD400	1/4-28	\$.75	HD4003	7/16-20	\$1.00	HD4006	5/8-18	\$1.50
HD4001	5/16-24	.75	HD4004	1/2-20	1.25	HD4007	3/4-16	2.00
HD4002	3/8-24	.75	HD4005	9/16-18	1.50	HD4008	7/8-14	3.00

### Nuts-Heavy Hex (Thick), N.C. Threads, Price each

HD4050	1/4-20	\$.20	HD4053	7/16-14	\$.30	HD4056	5/8-11	\$.50
HD4051	5/16-18	.20	HD4054	1/2-13	.30	HD5067	3/4-10	.85
HD4052	3/8-16	.25	HD4055	9/16-12	.35	HD5068	7/8-9	1.50

### Jam Nuts-Heavy Hex (Thin), N.C. Threads, Price each

HD410	1/4-20	\$.25	HD4103	7/16-14	\$.30	HD4106	5/8-11	\$.50
HD4101	5/16-18	.25	HD4104	1/2-13	.30	HD4107	3/4-10	.85
HD4102	3/8-16	.35	HD4105	9/16-12	.35	HD4108	7/8-9	1.50

### Square Nuts-Heavy, N.C. Threads, Price each

HD420	1/4-20	\$.30	HD4202	3/8-16	\$.50	HD4204	5/8-11	\$1.65
HD4201	5/16-18	.35	HD4203	1/2-13	1.05	HD4205	3/4-10	2.25

### Studs, steel- for heads, ignitors, bearing caps, etc.



1/4-20	Lng	\$	3/8-16	Lng	\$	1/2-13	Lng	\$
HD480	1 1/2	2.00	HD4809	1 1/2	2.00	HD4818	4	2.75
HD4801	2	2.00	HD4810	2	2.00	HD4819	5	3.00
HD4802	2 1/2	2.00	HD4811	3	2.00	<b>5/8-11 Lng \$</b>		
HD4803	3	2.00	HD4812	4	2.25	HD4821	2	2.25
<b>5/16-18 Lng \$</b>			HD4813	5	2.25	HD4822	2 1/2	2.50
HD4805	1 1/2	2.25	<b>1/2-13 Lng. \$</b>		HD4823	3	2.75	
HD4806	2	2.25	HD4815	1 1/2	2.00	HD4824	4	2.75
HD4807	2 1/2	2.25	HD4816	2	2.25	HD4825	5	3.00
HD4808	3	2.25	HD4817	3	2.50	HD4826	5 1/2	3.25

\*Other sizes available-please email or call for quote.

### Taper Pins

Part#	Size	Length	Large End dia.	Price
HD490	#0	2"	.114	\$1.50
HD491	#1	2"	.130	1.50
HD492	#2	2"	.151	1.50



\*Other sizes available upon request

### Woodruff Key

HD500	#1	1/16" X 1/2"	\$1.00
-------	----	--------------	--------



Most sizes available for mags, gears, etc.  
Call or email with size needed or application,  
for availability and price.

Music Wire, Spring-temper carbon steel wire-ideal for making coil springs for ignitors, etc. (Price for one 1 foot length)

Part#	Wire Dia.	Price	Part#	Wire Dia.	Price
HD350	.026	\$1.00	HD354	.045	\$1.50
HD351	.031	1.00	HD355	.051	1.50
HD352	.035	1.00	HD356	.055	1.50
HD353	.039	1.00	HD357	.063	1.50

Sheets, Brass and Copper-for general fabrication and forming.

HD450 Brass,	.025 thick	\$22.50 per sq. ft.
HD460 Copper,	.032 thick	46.00 per sq. ft.

### Shim Stock, Brass, 6" wide

HD470	.002	2.75 ft	HD4703	.010	\$3.90 ft
HD4701	.005	3.00 ft.	HD4704	.015	5.25 ft
HD4702	.007	3.50 ft.	HD4705	.020	6.00 ft

### Shim Stock, Steel, 6" wide

HD4710	.002	\$1.75 ft.	HD4713	.010	\$2.25 ft.
HD4711	.005	1.75 ft.	HD4714	.015	2.50 ft.
HD4712	.007	2.00 ft.	HD4715	.020	2.75 ft.